



DSP24N3/D is a display unit which shows the present temperature from temperature sensor type NTC. Up to three sensors can be connected. The set point can also be set on the unit.

- * Can be used together with a controller.
- * Or independently with a temperature sensor.
- * Selectable for different temperature ranges
- * Built-in setpoint adjustment
- * Distinct LED display
- * Only NTC sensors from our TG-series can be used

Function

DSP24N3/D is connected in parallel with the sensor to the controller's sensor input. Only NTC sensors from Regin's TG-series can be used. The unit has inputs for up to three sensors (three channels) and an output for external setpoint adjustment of a controller connected to it.

The value shown can be switched by means of the button on the front. The channel being shown is indicated by LEDs marked CH1, CH2, CH3 and SP (Setpoint).

DSP24N3/D can also be used without a controller. The sensors are then connected directly to the display unit.

The display unit is built into a standard casing for DIN rail mounting and has all settings easily accessible on the front.

Connected sensors

The unit is supplied with a set of labels on which the position or name of the sensor connected to a particular channel can be written. The function for the setpoint adjustment can also be noted in the square marked SP, for example "Setpoint Roomtemp." or "Not connected" when the setpoint is not activated. The label can be placed on the top of the unit or nearby.

Range

The range can be selected for each particular channel. Channel 1 can be set at 0...30, 20...50, 40...70 or 60...90° C, channel 2 at -30...+30 or 0...60°C and channel 3 at 0...30, 20...50, 40...70 or 60...90°C.

Setpoint

DSP24N3/D also has an output for external setpoint adjustment of a connected controller. The selected setpoint is shown in the display when the LED SP is lit. The setpoint range is the same as for sensor channel 1 (CH1) which is normally connected to the controller's principle sensor. If an external setpoint is not used the setpoint knob should be turned as far left as possible (min). The display will then show "0" when the LED SP is on. A label can also be used to show that the setpoint is not active.

Supply voltage

The unit is supplied with 24 V AC. When connecting to a controller it is important that 24 V system zero is correctly connected on the controller

Technical data

General

Supply voltage	24 V AC +/- 15 % 50-60 Hz
Power consumption	5 VA
Ambient temperature	0...50°C
Storage temperature	-40...50°C
Ambient humidity	Max 90%RH
Form of protection	IP20
Installation	To be mount on a DIN-rail, in a cabinet or other enclosure.

This product conforms with the requirements of European EMC standards CENELEC EN 50081-1 and EN 50082-1 and carries the CE mark.



Temperature ranges	Chanel 1 (CH1)	0...30, 20...50, 40...70, 60...90°C
	Chanel 2 (CH2)	0...60, -30...+30°C
	Chanel 3 (CH3)	0...30, 20...50, 40...70, 60...90°C
	Setpoint (SP)	The range is governed by the range set for chanle 1

(CH1)

Inputs

Sensor

Up to three sensors can be connected. Only NTC sensors from Regin's TG-series can be used, see leaflet 6-100. DSP24N3 can either be used using its own sensors, or together with a controller.

separately

Outputs

Setpoint

0...10 V to be connected to the input for external setpoint on the AQUA-controllers that have 0...10V outputs.

Function switches

Chanel 1 (CH1) and setpoint (SP)

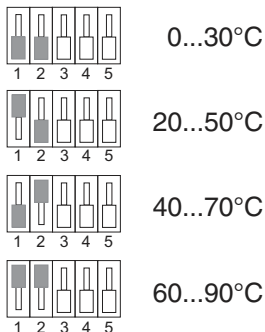

Chanel 2 (CH2)

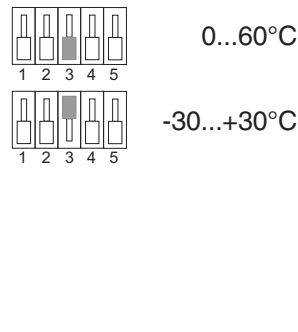

Chanel 3 (CH3)

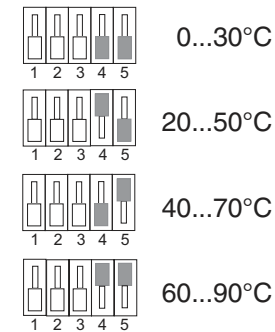

Wiring and dimensions

1	24V~ in	Supply voltage
2	Neutral	
3	CH1 in	
4	Signal neutral	
5	CH 2	
6	Signal neutral	
7	CH3 in	
8	Signal neutral	
9	0-10 VDC	Setpoint output
10	Neutral	
11	Not used	
12	Not used	

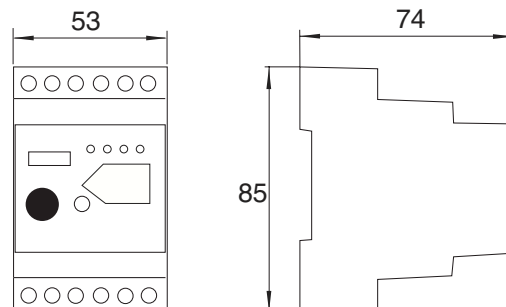

Head Office Sweden

Phone: +46 31 720 02 00
 Web: www.regin.se
 Mail: info@regin.se

Sales Offices

France: +33 14 171 46 46
 Hong Kong: +852 24 07 02 81
 Singapore: +65 67 47 82 33



THE CHALLENGER IN BUILDING AUTOMATION



FV1/D is an electronic frost protection unit for airhandling units. FV1/D is connected to a sensor placed in or near the heating coil.

- * Two alarm relays, 24 V and 230 V AC
- * Setpoint 0...15°C
- * Manual or automatic reset
- * Active output 0...10 V for control signal override
- * Supply 24 V AC
- * DIN-rail mounting

Functions

FV1/D is a frost protection unit mainly for use in air handling systems. The unit is connected to a REGIN NTC sensor that is placed in the heating coil or on the pipe from the coil. Sensor must be of temperature range 0...30 degrees, i.e. type TG-A130 or TG-D130.

To make a correct mounting and sensor choice, always follow recommendations from the water-heater supplier.

Alarm setpoint

Setpoint range is 0...15°C and can be set on the front of the unit using a screwdriver. Normal setpoint for frost protection in air handling systems is between 5...8°C.

Active output Y1

To prevent frost alarm, FV1/D has a function that over-modulates the signal to the control valve. If the temperature at the frost protection sensor begins to reach the alarm level the FV1/D will start to force the control valve to open. If the temperature falls below the start-point * for active output, the output signal will successively increase. If the temperature continues to fall, the output signal will continue to increase. When the temperature has fallen to the alarm level, the output signal is +10 V DC.

* The start-point level is the set alarm level plus 5 K.

Connection of an output from the controller

The control signal from the controller connects to the input at the FV1/D. FV1/D has an analogue output which connects to the control signal input on the actuator.

Frost alarm

If the temperature at the temperature sensor falls below alarm setpoint both alarm relays trip and the alarm LED comes on.

Reset

When the temperature rises to a level 5K above the alarm setpoint, the alarm can be reset by pushing the reset button.

Automatic reset

FV1/D can easily be set to have automatic reset if desired, instead of manual reset. *See overleaf.*

Technical data

General

Supply voltage	24 V AC +/- 15%
Power consumption	2 VA
Ambient temperature	0...50°C
Storage temperature	-40...+50°C
Ambient humidity	Max 90%RH
Protection class	IP20



This product conforms with the European EMC standards CENELEC EN50081-1 and EN50082-1 and carries the CE-mark.

Inputs

Sensor	Regin NTC sensor, 0...30°C ranges
Automatic/remote reset	Potential free closing contact between terminals 2 and 3

Outputs

Relays	24 V AC 1 A, change-over and 230 V AC 1 A, breaking contact
Control signal	0...10 V

Setting

Setpoint	0...15°C
P-band, control signal override	5 K, fixed

Automatic resetting adjustment

FV1/D has manual resettings as standard. If automatic reset is required the following instruction will guide you:

Drill a 3 mm Ø hole in the printed circuit board via the guide-hole in the middle of the bottom plate of the FV1/D.

Be careful, drill only a few millimeters into the board. This will cut a wire and automatic resetting will occur when the temperature rises above setpoint plus 5 K. This step must be done before the FV1/D is installed and connected to supply voltage.

N.B. Be sure that no voltage is connected!

Wiring

1	Supply voltage 24V AC	
2	System neutral	
3	Input 0..10 V from controller	
4	Not connected	
5		Relay
6		230V AC / 1A
7	Frost protection sensor	
8	Signal neutral	
9	Y1 0..10V DC Output	
10		Relay
11		24V AC / 1A
12		

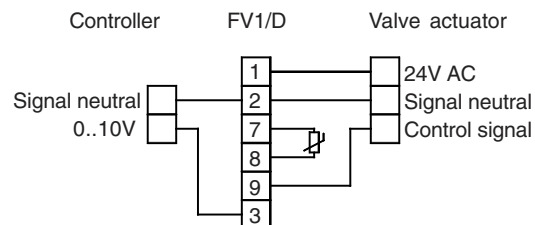

Wiring example with active output via FV1/D

N.B. The relay switches are shown deenergized = alarm mode

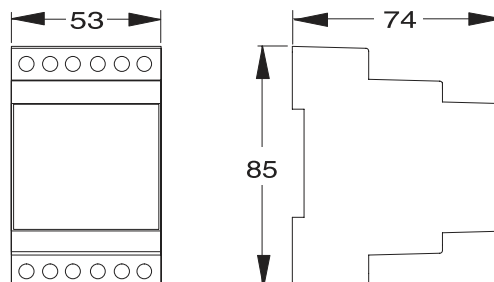

Head Office Sweden

Phone: +46 31 720 02 00
 Web: www.regin.se
 Mail: info@regin.se

Sales Offices

France: +33 14 171 46 46
 Hong Kong: +852 24 07 02 81
 Singapore: +65 67 47 82 33



THE CHALLENGER IN BUILDING AUTOMATION



TI-N is a wall mounted room thermostat for controlling in HVAC systems. The thermostat can control fans, cooling units, electric heaters fans etc.

- * Change-over contact, 10A 250 V AC
- * Cooling or heating function
- * Protection class IP30
- * Temperature range 5...30°C
- * Setting-range can be mechanically limited
- * Hysteresis 0.6 K

Function

TI-N is an electromechanical thermostat for room mounting. The thermostat contains a pair of gas-filled bellows with a stainless steel membrane which reacts to a change in temperature by creating a movement which is transmitted to the switch. The thermostat can control a heating or cooling function.

Setpoint

The thermostat has a temperature range of 5°C to 30°C. If required the range can be limited by means of mechanical endstops behind the setting knob.

Mounting

The thermostat has mounting holes of cc 60mm and can be mounted on a standard wallbox.

Technical data

Ambient temperature	0...50°C
Storage temperature	-40...+50°C
Ambient humidity	Max 90% RH
Form of protection	IP30
CE	This product conforms with the LVD standards IEC 669-1 and carries the CE mark
Output	
Relay	One changeover contact, 10 (2,5) A 250 V AC
Setting	
Setpoint	5...30°C, mechanically limited
Hysteresis	0,6K, fixed

Wiring and dimensions

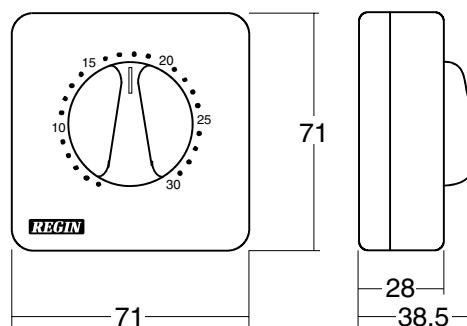
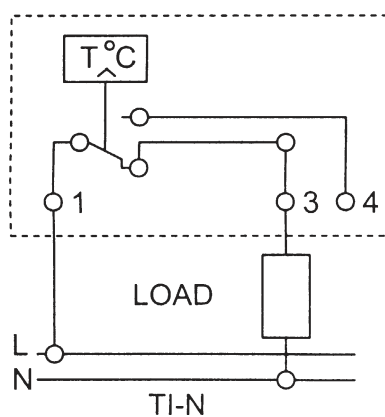

Terminal 1	250 V in
Terminal 2	Heating out
Terminal 3	Cooling out

N.B. TI-N can be used for either heating or cooling, not both at the same time.

Head Office Sweden

Phone: +46 31 720 02 00
Web: www.regin.se
Mail: info@regin.se

Sales Offices

France: +33 14 171 46 46
Hong Kong: +852 24 07 02 81
Singapore: +65 67 47 82 33

REGIN

THE CHALLENGER IN BUILDING AUTOMATION



RRT025A

Room thermostat with fan switch

RRT025A is a wall mounted room thermostat for controlling fan coils. The thermostat has a switch for controlling fan speed. Another switch selects heating or cooling mode.

- Closing contact, 4 A (2A) 230 V AC
- Cooling or heating function
- On-off switch

RRT025A is an electro-mechanical thermostat for room mounting. The sensing element is a pair of gas-filled bellows with a stainless steel membrane which reacts to a change in temperature by creating a movement which is transmitted to the switch. The thermostat can be used for cooling or heating application. RRT025A also has a fan switch with three positions.

Setpoint

The thermostat has a temperature range of 10...30°C.

- Fan switch with three positions
- Temperature range 10...30°C
- Easy to install

Mounting

The thermostat has mounting holes of cc 60 mm and can be mounted on a standard wallbox.

Applications

Can be used in fan-coil units, with cooling and/or heating function.

Technical data

Sensor element	Unipolar gas filled bellow
Ambient temperature	0...40°C
Storage temperature	-40...+50°C
Ambient humidity	Max 90% RH



The product conforms with the requirements of the European LVD standard IEC 60 730-2-9 and carries the CE-mark.

Outputs

Thermostat	One closing contact
Circuit breaking capacity	4 (2) A, 230 V AC (Total load, actuator + fan)

Settings

Setpoint	10...30 °C
Hysteresis	0.6 K, fixed
Protection class	IP20

Connection

1	Supply voltage 230 V AC
2	Fan, medium speed
3	Fan, low speed
4	Neutral
5	Heating / Cooling output
6	Fan, high speed

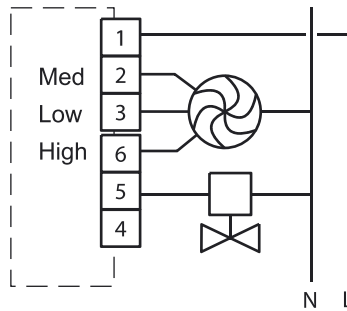

Dimensions

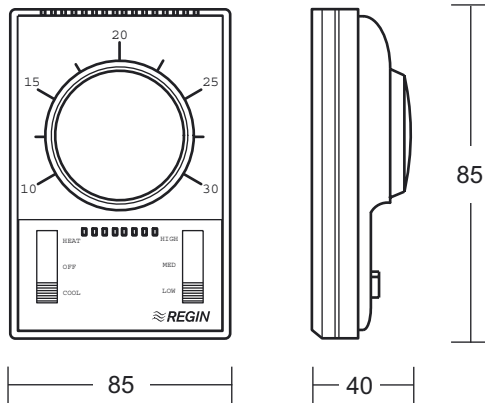



TM1-IT/D is intended for melting ice in roof gutters or other weather exposed constructions.

- * Supply voltage 230 V AC
- * Output 230 V AC, 16 A
- * Protection against icicle build-up
- * Settable switch-off delay
- * DIN-rail mounting
- * For outdoor sensor, TG-R600

Function

TM1-IT/D is an electronic single stage ice-thermostat with adjustable switching points and deactivation delay, intended for DIN-rail mounting.

The thermostat is intended for melting ice in roof gutters, outdoor stairs etc. using electric heating cables. This to eliminate the risk of icicle build-up.

Sensor

The thermostat is to be connected to an outdoor sensor type TG-R600.

Switch-off delay

The thermostat has a switch-off delay function settable between 10 sec...10 min.

Function

The output is activated when outdoor temperature is between set limit values. See figure below.

For more information about settings, see overleaf.

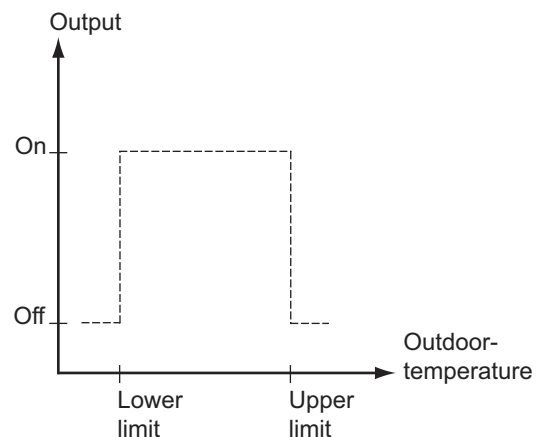

Technical data

Supply voltage 230 V AC

Output

Relay output 230 V AC, 16 A, closing relay

Input

Sensor input One, intended for sensor TG-R600

Settings

Upper limit 0...+20°C, Upper switching temperature

Lower limit -20...0°C, Lower switching temperature

Off delay 10 sec...10 min, Deactivation delay time

Protection class IP30



This product conforms with the requirements of European EMC standards CENELEC EN 61000-6-1, EN 61000-6-3 and European LVD standards IEC 60 730-2-9 and carries the CE-mark.

Wiring and dimensions

1	230 V AC	Supply voltage
2	230 V AC	
3	Not connected	
4	Not connected	
5	Relay 16A, 230V AC	
6		
7	Temperature sensor	
8	Signal neutral	
9	Not connected	
10	Not connected	
11	Not connected	
12	Not connected	

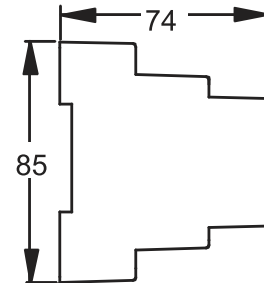
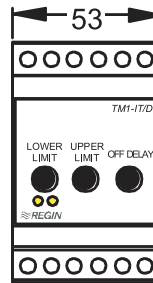

(mm)

Head Office Sweden

Phone: +46 31 720 02 00

Web: www.regin.se

Mail: info@regin.se

Sales Offices

France: +33 14 171 46 46

Hong Kong: +852 24 07 02 81

Singapore: +65 67 47 82 33



THE CHALLENGER IN BUILDING AUTOMATION



TM2HC/D is an electronic thermostat designed for controlling heating and cooling applications

- * One stage heating and one stage cooling in sequence
- * Supply voltage 24 V AC or 230 V AC
- * Adjustable neutral zone
- * Internal or external setpoint

Function

TM2HC/D is an electronic thermostat to be used in conjunction with Regin temperature sensors. The thermostat has change over relay outputs for applications with both heating and cooling with adjustable neutral zone. TM2HC/D can be used with supply voltage 24 V AC or 230 V AC. TM2HC/D is supplied in standard casing for DIN-rail mounting with all settings accessible on the front.

Setpoint

The setpoint is set by means of the setpoint knob on the front or by means of the external setting device. TM2HC/D has a standard scale of 0...30°C. The setpoint is the temperature at which the relay H1 is deenergized.

Other scales adapted for other sensor ranges are available.

When an external setting device, e.g. TG-R430 or TBI-30, is used the built-in setpoint must be set at the counter clockwise end position.

Sensors

The TM2HC/D is intended for a sensor temperature range 0...30°C but other temperature ranges are available. See leaflet 6-100 in the main catalogue for choice of sensors.

Hysteresis

The difference in temperature between a relay's ON-point and OFF-point is fixed at 0.5K and is the same for both relays.

Neutral zone (NZ)

The difference in temperature between the relay's OFF-points is adjustable between 0.5...10K.

Indicators

TM2HC/D has LEDs to indicate supply voltage on and relay output activation. Red = heating and green = cooling.

Night Set-back

Night set-back can be initiated by means of an external time switch together with the night set-back module NS/D. See separate leaflet. This module allows night set-back to be set between 0...10 K.

Technical data

General

Supply voltage	24 V AC or 230 V AC +/- 15 % 50-60 Hz
Power consumption	Max. 5 VA
Ambient temperature	0...50°C
Storage temperature	-40...+50°C
Ambient humidity	Max. 90% RH
Form of protection	IP20



This product conforms with the requirements of European EMC standards CENELEC EN 50081-1 and EN 50082-1, European LVD standards IEC 669-1 and IEC 669-2-1 and carries the CE mark.

Inputs

Sensor One input for main sensor. Only for Regin NTC-sensors. See leaflet 6-100 for choice of sensor.

Setpoint When using an external setpoint the setpoint device should be connected in series with the sensor to the sensor input. Setpoint knob on TM2HC/D must be set to 0.

Night set-back If night set-back is required the NS/D should be used together with a timer.

Outputs

Relays Two SPDT (change over) relays, 230 V AC 5 (2) A. When a relay is activated the corresponding LED comes on.

Hysteresis Fixed 0.5K.

Settings

Setpoint 0...30°C. The choice of sensor determines the thermostat's setpoint range

Neutral zone 0.5...10 K. The difference between the relay's OFF-points.

Wiring and dimensions

1		Relay H1 heating
2		
3		5(2)A 230V AC
4		Not connected
5		Not connected
6		Relay C1 cooling
7		
8		5(2)A 230V AC
9		Not connected
10		Not connected
11		Not connected
12		Not connected

13	Temperature sensor	
14	Signal neutral	
15	Signal neutral	
16	Signal neutral	
17	Signal neutral	
18	Signal neutral	
19	Signal neutral	
20	24V AC in	Supply
21	Syst. neutral	voltage
22	Not connected	
23	230V AC	Supply
24		voltage

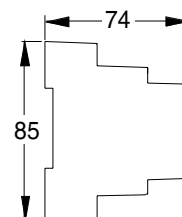
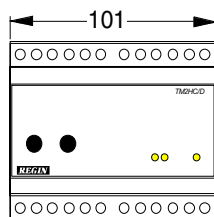

mm



TM4HC/D is an electronic thermostat designed for controlling heating and cooling applications

- * Two stages heating and Two stages cooling in sequence
- * Supply voltage 24 V AC or 230 V AC
- * Adjustable neutral zone
- * Internal or external setpoint

Function

TM4HC/D is an electronic thermostat to be used in conjunction with Regin temperature sensors. The thermostat has relay outputs for applications with both heating and cooling with adjustable neutral zone. TM4HC/D can be used with supply voltage 24 V AC or 230 V AC. TM4HC/D is supplied in standard casing for DIN-rail mounting with all settings accessible on the front.

Setpoint

The setpoint is set by means of the setpoint knob on the front or by means of the external setting device. TM4HC/D has a standard scale of 0...30°C. The setpoint is the temperature at which the relay H1 is deenergized.

Other scales adapted for other sensor ranges are available.

When an external setting device, e.g. TG-R430 or TBI-30, is used the built-in setpoint must be set at the counter clockwise end position.

Sensors

The TM4HC/D is intended for a sensor temperature range 0...30°C but other temperature ranges are available. See leaflet 6-100 in the main catalogue for choice of sensors.

Hysteresis

The difference in temperature between a relay's ON-point and OFF-point is fixed at 0.5K and is the same for all relays.

Neutral zone (NZ)

The difference in temperature between the relay's OFF-points is adjustable between 0.5...10K.

Step differential (SD)

The step differential between the heating relays and between the cooling relays is 1K fixed.

Indicators

TM4HC/D has LEDs to indicate supply voltage on and relay output activation. Red = heating and green = cooling.

Night Set-back

Night set-back can be initiated by means of an external time switch together with the night set-back module NS/D. See separate leaflet. This module allows night set-back to be set between 0...10 K.

Technical data

General

Supply voltage	24 V AC or 230 V AC +/- 15 % 50-60 Hz
Power consumption	Max. 5 VA
Ambient temperature	0...50°C
Storage temperature	-40...+50°C
Ambient humidity	Max. 90% RH
Form of protection	IP20



This product conforms with the requirements of European EMC standards CENELEC EN 50081-1 and EN 50082-1, European LVD standards IEC 669-1 and IEC 669-2-1 and carries the CE mark.

Inputs

Sensor	One input for main sensor. Only for Regin NTC-sensors. See leaflet 6-100 for choice of sensor.
Setpoint	When using an external setpoint the setpoint device should be connected in series with the sensor to the sensor input. The setpoint knob on TM4HC/D must be set to 0. If night set-back is required the NS/D should be used together with a timer.
Night set-back	

Outputs

Relays	Four. Two SPDT (change over) relays (one for heating and one for cooling) and two closing relays (one for heating and one for cooling), 230 V AC 5 (2) A. When a relay is activated the corresponding LED comes on.
Hysteresis	Fixed 0.5K.
Step differential (SD)	Fixed 1K. Between the heating and between the cooling relays.

Settings

Setpoint	0...30°C. The choice of sensor determines the thermostat's setpoint range
Neutral zone	0.5...10 K. The difference in temperature between the OFF-points for relays C1 and H1.

Wiring and dimensions

1		Relay H1 heating
2		Relay H2
3		5(2)A 230V AC
4		Relay C1 cooling
5		5(2)A 230V AC
6		Relay C2
7		5(2)A 230V AC
8		5(2)A 230V AC
9		5(2)A 230V AC
10		5(2)A 230V AC
11		Not connected
12		Not connected

13	Temperature sensor	
14	Signal neutral	
15	Signal neutral	
16	Signal neutral	
17	Signal neutral	
18	Signal neutral	
19	Signal neutral	
20	24V AC in	Supply voltage
21	Syst. neutral	voltage
22	Not connected	
23		Supply voltage
24	230V AC	

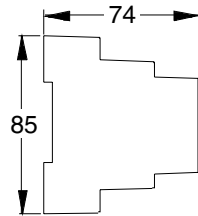
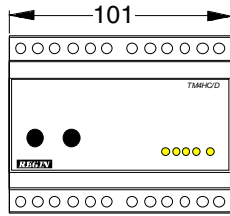

mm

Head Office Sweden
 Phone: +46 31 720 02 00
 Web: www.regin.se
 Mail: info@regin.se

Sales Offices
 France: +33 14 171 46 46
 Hong Kong: +852 24 07 02 81
 Singapore: +65 67 47 82 33

