

NRW

Water-cooled water chillers, heat pumps and moto-evaporating units
With capacities from 5.5 to 38.29 kW

R407C



Aermec adheres to the EUROVENT Certification Programme. The products concerned appear in the EUROVENT Certified Products Guide.



Features

- Available in 7 sizes
- Versions:
 - NRW:** cooling only
 - NRW S:** as above but without pressure switch valve
 - NRW E:** evaporator unit. The units are despatched after being pre-charged.
 - NRW A:** with circulation pump and 100-litre storage tank (for models NRW 57-77-107 and 127)
 - NRW H:** heat pump
 - NRW HS:** as above but without pressure switch valve

- **NRW HA:** with circulation pump and 100-litre water tank (for models NRW 57-77-107 and 127)
- Cycle reversal on refrigerant circuit
- The versions with storage tank (standard for models NRW 27-37 and 47 designed for wall installation and with a capacity of 35 litres) are equipped with circulation pump, water tank, expansion tank, water filter and safety valve)
- Complies with EEC Safety Directive (CE) and electromagnetic compatibility directive
- High efficiency rotary, scroll and reciprocating compressors with low power consumption

- Differential pressure switch supplied as standard on all models
- Modular microprocessor control system
- Straightforward intuitive control panel
- High efficiency plate type heat exchangers
- Compact size
- Metallic protective cabinet with rustproof polyester paint
- Internal lining and compressor compartment lining in flame-retardant sound insulating material

Accessories

- **PGS:** Daily/weekly programmer with facility to program two daily on/off cycles and set different parameters for each day of the week.
- **PR3:** Remote control panel with ON/OFF, operating mode selection (cooling / heating) and general alarm indication.
- **VP:** Pressure switch valve complete with connections, piloted directly in relation to condensation pressure; the valve modulates the

- volume of water needed to cool the condenser, thereby maintaining the condensation temperature unchanged.
- **VPH:** Pressure switch valve with bypass solenoid valve: during cooling mode operation the bypass valve is closed so the water flows exclusively through the circuit with the pressure switch. During heating mode operation the water flows through both branches of the circuit.

- **VT:** Anti-vibration mounts; set of four mounts to install in locations under the baseplate of floor-standing units to attenuate the transmission of vibration generated by the compressor.

Mod. NRW	Compatibility of accessories									
	PR3	PGS	VP 6	VP 7	VP 8	VPH 6	VPH 7	VPH 8	VT 7	VT 9*
27 - 37 - 47	✓	✓								
27 S - 37 S - 47 S	✓	✓								
27 E - 37 E - 47 E	✓	✓								
27 H - 37 H - 47 H	✓	✓								
27 SH - 37 SH - 47 SH	✓	✓								
57 - 57 A	✓	✓	✓						✓	✓
57 E - 57 EA	✓	✓							✓	✓
57 H - 57 HA	✓	✓				✓			✓	✓
77 - 77 A	✓	✓	✓						✓	✓
77 E - 77 EA	✓	✓							✓	✓
77 H - 77 HA	✓	✓				✓			✓	✓
107 - 107 A	✓	✓		✓					✓	✓
107 E - 107 EA	✓	✓							✓	✓
107 H - 107 HA	✓	✓					✓		✓	✓
127 - 127 A	✓	✓			✓				✓	✓
127 E - 127 EA	✓	✓						✓	✓	✓
127 H - 127 HA	✓	✓						✓	✓	✓

* = To be used in place of the accessory VT 7 on versions with accumulators (A).

Technical data

Mod. NRW		27	37	47	57	57 A	77	77 A	107	107 A	127	127 A
Cooling capacity	kW	6.0	7.7	10.1	13.2	13.2	20.5	20.5	26.4	26.4	37.5	37.5
Total input power	kW	1.9*	2.85*	3.2*	3.7	4.2*	5.1	5.7*	8	8.6*	10.3	11*
Input current	A (230V)	8.8	14.7	16	–	–	–	–	–	–	–	–
	A (400V)	–	6.9	6.8	7.4	8.3	9.5	10.5	15	16.1	18	19.2
E.E.R.	W/W	3.16	2.7	3.16	3.57	3.14	4.02	3.6	3.3	3.07	3.64	3.42
Evaporator water flow rate	l/h	1030	1320	1740	2270	2270	3530	3530	4540	4540	6450	6450
Effective pressure to the installation circ.	kPa	66.5	77	65	–	92	–	78	–	55	–	49
Evaporator pressure drop	kPa	–	–	–	32	–	30	–	29	–	34	–
Condenser water consumption	l/h	1360	1810	2230	2910	2910	4400	4400	5920	5920	8220	8220
Condenser pressure drop	kPa	24	66	34	70	43	65	65	66	66	57	57
Condenser water consumption (16 °C)	l/h	300	383	500	642	642	920	920	1260	1260	1727	1727
Condenser water pressure drops (16 °C)	kPa	2.0	3.0	1.7	3.4	3.4	3.2	3.2	3.0	3.0	2.6	2.6
Refrigerant charge	kg	0.92	0.65	0.99	1.01	1.01	1.8	1.8	2.65	2.65	3.25	3.25
♪ Sound pressure	dB(A)	47	48.5	49.5	48	48	56	56	62	62	56	56
Evaporator water contents	l	0.75	0.75	0.94	1.03	1.03	1.79	1.79	2.44	2.44	3.1	3.1
Evaporator water connections	Ø Gas	1"/F	1"/F	1"/F	1"/M	1"/M	1"/M	1"/M	1"/M	1"/M	1"/M	1"/M
Condenser water contents	l	0.56	0.56	0.94	0.85	0.85	1.5	1.5	1.79	1.79	2.44	2.44
Condenser water connections	Ø Gas	1"/F	1"/F	1"/F	1"/M	1"/M	1"/M	1"/M	1"/M	1"/M	1"/M	1"/M
Capacity of water accumulator	l	35	35	35	–	100	–	100	–	100	–	100
Compressor	type	Rotary	Scroll	Scroll	Scroll	Scroll	Scroll	Scroll	Scroll	Scroll	Scroll	Scroll
Max. current	A (230V)	11	18	22.7	–	–	–	–	–	–	–	–
	A (400V)	–	8	8.9	13	13.9	14	15	20	21.1	32	33.2
Peak current	A (230V)	47	95	116	–	–	–	–	–	–	–	–
	A (400V)	–	43.5	52	66	66	102	102	130	130	135	135

Mod. NRW		27 H	37 H	47 H	57 H	57 HA	77 H	77 HA	107 H	107 HA	127 H	127 HA
Cooling capacity	kW	6	7.3	10	13.3	13.3	19.6	19.6	25	25	37	37
Total input power	kW	1.9*	2.6*	3.7*	3.7	4.1*	5.1	5.55*	8	8.5*	10.3	10.9*
Input current	A (230V)	8.8	13.3	16.2	–	–	–	–	–	–	–	–
	A (400V)	–	6.1	7	7.4	8.3	9.5	10.5	15	16.1	18	19.2
E.E.R.	W/W	3.16	2.81	3.16	3.64	3.24	3.88	3.53	3.14	2.94	3.61	3.39
Evaporator water flow rate	l/h	1030	1260	1740	2290	2290	3370	3370	4300	4300	6360	6360
Effective pressure to the installation circ.	kPa	65	22	73	–	91	–	82	–	62	–	51
Evaporator pressure drop	kPa	–	–	–	32	–	28	–	27	–	34	–
Condenser water consumption	l/h	1360	1700	2230	2920	2910	4240	4230	5670	5660	8130	8130
Condenser pressure drop	kPa	24	31	34	50	50	41	41	43	43	51	51
Condenser water consumption (16 °C)	l/h	300	359	500	642	647	920	920	1260	1260	1727	1727
Condenser water pressure drops (16 °C)	kPa	2.0	1.4	1.7	3.4	3.4	3.2	3.2	3.0	3.0	2.6	2.6
Heating capacity	kW	6.9	9.8	11.7	15.9	15.9	26.8	26.8	32	32	44.5	44.5
Total input power	kW	2.34*	3.7*	4.4*	5	5.5*	7.5	8.05*	10.6	11.2*	13	13.65*
Input current	A (230V)	10.6	17.8	21	–	–	–	–	–	–	–	–
	A (400V)	–	7.5	8	9	9.85	13.9	14.88	18.3	19.35	21.8	23
C.O.P.	W/W	2.95	2.65	2.66	3.18	2.89	3.57	3.33	3.02	2.86	3.42	3.26
Condenser water flow rate	l/h	1190	1690	2010	2730	2730	4610	4610	5500	5500	7650	7650
Effective pressure to the installation circ.	kPa	63	36	69	–	90	–	65	–	50	–	48
Condenser pressure drop	kPa	–	–	–	42	–	47	–	40	–	44	–
Evaporator water consumption (10 °C)	l/h	810	1050	1300	1870	1870	3320	3320	3680	3680	5520	5418
Evaporator pressure drop	kPa	9	16	31	22	22	27	27	19	19	24	24
Refrigerant charge	kg	1	0.75	1.0	1.24	1.24	2	2	3.4	3.4	4.5	4.5
♪ Sound pressure	dB(A)	47	49	49.5	48	48	56	56	62	62	56	56
Evaporator water contents	l	0.75	0.75	0.94	1.03	1.03	1.79	1.79	2.44	2.44	3.1	3.1
Evaporator water connections	Ø Gas	1"/F	1"/F	1"/F	1"/M	1"/M	1"/M	1"/M	1"/M	1"/M	1"/M	1"/M
Condenser water contents	l	0.75	0.75	0.94	0.85	0.85	1.50	1.50	1.79	1.79	2.44	2.44
Condenser water connections	Ø Gas	1"/F	1"/F	1"/F	1"/M	1"/M	1"/M	1"/M	1"/M	1"/M	1"/M	1"/M
Capacity of water accumulator	l	35	35	35	–	100	–	100	–	100	–	100
Compressor	type	Rotary	Scroll	Scroll	Scroll	Scroll	Scroll	Scroll	Scroll	Scroll	Scroll	Scroll
Max. current	A (230V)	11	18	22.7	–	–	–	–	–	–	–	–
	A (400V)	–	8	8.9	13	13	14	14	20	20	32	32
Peak current	A (230V)	47	95	116	–	–	–	–	–	–	–	–
	A (400V)	–	43.5	52	66	66	102	102	130	130	135	135

Power supply = 1~ 230V 50Hz; 3N~ 400V 50Hz.

Performance values refer to the following conditions:

♪ Sound pressure measured in an 85 m³ semi-reverberant test chamber with reverberation time Tr = 0.5s.

■ Cooling:

- processed water temperature 7 °C;
- water inlet temperature to condenser 30 °C;
- Δt = 5 °C.

■ Heating:

- processed water temperature 50 °C;
- water inlet temperature to evaporator 10 °C;
- Δt = 5 °C.

* including circulator pump power consumption.

Technical data

Mod. NRW		27 E	37 E	47 E	57 E	57 EA	77 E	77 EA	107 E	107 EA	127 E	127 EA
Cooling capacity	kW	5.7	7.45	10	12.9	12.9	19.8	19.8	25.7	25.7	36.5	36.5
Total input power	kW	2.1*	3.1*	3.4*	3.8	4.3*	5.2	5.7*	8.2	8.75*	10.5	11.1*
Input current	A (230V)	9.6	15.2	16.4	–	–	–	–	–	–	–	–
	A (400V)	–	7.1	6.9	7.8	8.7	10	11	15.8	16.9	19	20.2
E.E.R.	W/W	2.71	2.44	2.94	3.39	3	3.84	3.47	3.15	2.94	3.49	3.29
Evaporator water flow rate	l/h	980	1280	1720	2220	2220	3410	3410	4420	4420	6280	6280
Effective pressure to the installation circ.	kPa	66	23	77	–	94	–	81	–	66	–	52
Evaporator pressure drop	kPa	–	–	–	31	–	28	–	29	–	33	–
Refrigerant charge	kg	0.05	0.01	0.05	0.1	0.1	0.1	0.1	0.1	0.1	0.1	0.1
♪ Sound pressure	dB(A)	47	48.5	49.5	48	48	56	56	62	62	56	56
Evaporator water contents	l	0.75	0.75	0.94	1.03	1.03	1.79	1.79	2.44	2.44	3.1	3.1
Evaporator water connections	Ø Gas	1"/F	1"/F	1"/F	1"/M	1"/M	1"/M	1"/M	1"/M	1"/M	1"/M	1"/M
Capacity of water accumulator	l	35	35	35	–	100	–	100	–	100	–	100
Gas line	Ø mm	12.7	12.7	12.7	12.7	12.7	18	18	18	18	22	22
Liquid line	Ø mm	9.52	9.52	9.52	12.7	12.7	12.7	12.7	12.7	12.7	12.7	12.7
Compressor	type	Rotary	Scroll	Scroll	Scroll	Scroll	Scroll	Scroll	Scroll	Scroll	Scroll	Scroll
Max. current	A (230V)	11	18.9	22.7	–	–	–	–	–	–	–	–
	A (400V)	–	8.4	8.9	13	13	14	14	20	20	32	32
Peak current	A (230V)	47	95	116	–	–	–	–	–	–	–	–
	A (400V)	–	43.5	52	66	66	102	102	130	130	135	135

Power supply = 1~ 230V 50Hz; 3N~ 400V 50Hz.

Performance values refer to the following conditions:

♪ Sound pressure measured in an 85 m³ semi-reverberant test chamber with reverberation time Tr = 0.5s.

* including circulator pump power consumption.

■ Cooling (NRW E):

- condensation temperature 45 °C
- processed water temperature 7 °C;
- Δt = 5 °C.

Dimensions (mm)

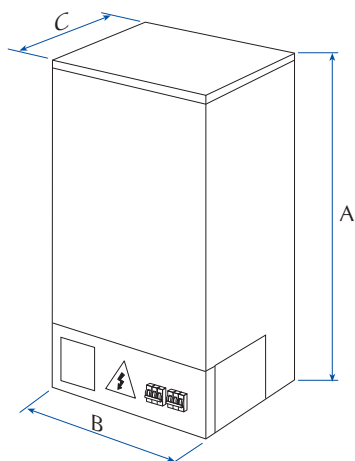

NRW 27 - 37 - 47

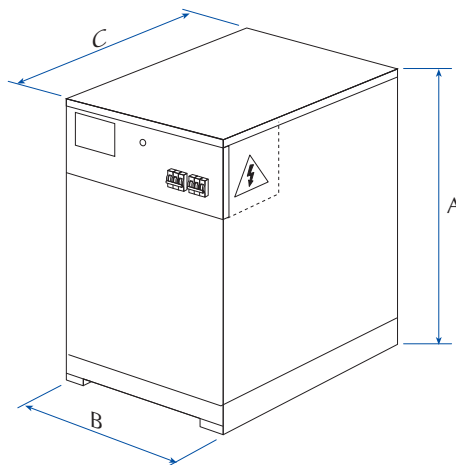

NRW 57 - 77 - 107 - 127

NRW (all versions)		27	37	47	57	57 A	77	77 A	107	107 A	127	127 A
Height	A	1140	1140	1140	850	1000	850	1000	950	1000	950	1000
Width	B	450	450	450	450	1100	450	1100	450	1100	450	1100
Depth	C	450	450	450	650	750	650	750	700	750	700	750
Weight (kg)	NRW	98	110	117	98	-	120	-	155	-	183	-
	NRW E	93	106	112	91	-	110	-	143	-	166	-
	NRW H	101	112	118	102	-	124	-	160	-	189	-
	NRW A	-	-	-	-	188	-	202	-	253	-	270
	NRW EA	-	-	-	-	184	-	198	-	246	-	260
	NRW HA	-	-	-	-	192	-	206	-	258	-	276