

NRL

Chillers and air-cooled heat pumps with axial flow fans
Capacity from 462 to 944 kW



R410A



Aermec adheres to the EUROVENT Certification Programme. The products concerned appear in the EUROVENT Certified Products Guide.



- **HIGH EFFICIENCY VERSION**
- **SILENCED HIGH EFFICIENCY VERSION**
- **COMPACT VERSION**
- **SILENCED COMPACT VERSION**

- **4 COOLING CIRCUITS**
- **CIRCULATION PUMP**
- **CIRCULATION PUMP**
- **E ACCUMULATOR TANK**

Characteristics

- Available in 7 sizes.
- Refrigerant R410A.
- 4 Cooling circuits.
- High efficiency even with partial loads.
- Heat exchangers optimised to exploit the excellent heat transfer characteristics of the R410A.
- High-efficiency scroll compressors.
- Axial flow fans with reduced noise level.
- Solid construction with polyester anticorrosion painted finish.
- Extended operating limits with heat pump functioning:
 - Max. processed water temperature 55° C.
 - Max. external air temperature 30° C. (42° C with speed regulator accessory for DCPX fans).
- Versions available:
 - "H" Standard compact heat pump.
 - "HL" Silenced compact heat pump.
 - "HA" High efficiency heat pump.
- "HE" High-efficiency silenced heat pump.
- Thermostatic valve (selectable with configurator):
 - "O" standard mechanical thermostatic valve.
 - "X" electronic thermostatic valve, also for low water temperature (down to -6°C).
- Fan unit (selectable with configurator):
 - "O" Standard.
 - "M" Enlarged.
 - "J" Inverter.
- Versions with pumping assembly and tanks complete with water filter, flow switch, expansion tank, a charging unit and antifreeze electric heater.
- Microprocessor control system:
 - Control of the inlet water temperature, with the possibility of selecting the control of the outlet water.
 - Summer condensation control with 0-10V modulating signal depending on

- pressure, compensated according to the outside air temperature (with DCPX accessory).
- Evaporation control for the heat pump summer operation (with DCPX accessory).
- Auto rotation of compressors and pumps according to operating hours (for all sizes)
- Safety capacity control.
- Low and high pressure transducers (standard for all versions).
- Automatic reset of alarms before total block.
- Messages in 4 languages.
- Alarm Log.

Accessories

- **AER485:** RS-485 interface for supervision systems with MODBUS protocol.
- **AVX:** Sprung anti-vibration supports. Select the AVX model from the compatibility table.
- **DCPX:** With this accessory correct operation is possible with outside temperatures below 10 °C and down to - 10 °C. It is made up of an electronic regulation card that varies the fan rpm on the basis of the condensation pressure, read by the high pressure transducer in order to keep it sufficiently high for the proper functioning of the unit. It also allows correct heating operation with outside temperatures greater than 30°C and up to 42°C.
- **DRE:** Electronic starting current reduction device. **Can only be installed in the factory.**
- **GP:** Protection grille, protects external coils from accidental knocks.
- **PGS:** Daily/Weekly Programmer.
 - Allows you to programme two time bands per day (two switch on/off cycles) and to have differentiated programming for each day of the week.
- **RIF:** Current rephaser. Parallel connection with the motor makes the reduction of input current possible. **This can only be installed when the machine is being made and must therefore be specified when the order is placed.**
- **AERWEB30:** The AERWEB device allows remote control of a chiller via a serial link from a standard PC. Using additional modules, the device allows to control the chiller via the telephone network, using the **AER-MODEM** accessory; or via the GSM network, using the **AERMODEMGSM** accessory. AERWEB can pilot up to 9 chillers, but each of these **must** be equipped with the AER485 or AER485P2 accessory.
- **DUALCHILLER:** Simplified control system to switch on and off, and command, two chillers (using Aermec GR3 command) in a single system, as if they were a single unit.
- **MULTICHILLER:** Control system to switch the individual chillers on and off, and command them, in a system in which several units are installed in parallel, always ensuring a constant delivery to the evaporators.
- **TRX1:** Metal cap that replaces the plastic cap, mounted for protection in accumulators with holes and supplementary electric heaters.
- **PRM1-PRM2:** FACTORY FITTED ACCESSORY. It is a manual pressure switch electrically wired in series with the existing automatic high pressure switch on the compressor discharge pipe.

Compatibility of accessories

| Mod. NRL | Vers. | 2000 | 2250 | 2500 | 2800 | 3000 | 3300 | 3600 |
|--------------|---------|------------|------------|------------|------------|------------|------------|------------|
| AER485 | All | ✓ | ✓ | ✓ | ✓ | ✓ | ✓ | ✓ |
| DUALCHILLER | All | ✓ | ✓ | ✓ | ✓ | ✓ | ✓ | ✓ |
| MULTICHILLER | All | ✓ | ✓ | ✓ | ✓ | ✓ | ✓ | ✓ |
| PGS | All | ✓ | ✓ | ✓ | ✓ | ✓ | ✓ | ✓ |
| AERWEB30 | All | ✓ | ✓ | ✓ | ✓ | ✓ | ✓ | ✓ |
| TRX1 | All | ✓ | ✓ | ✓ | ✓ | ✓ | ✓ | ✓ |
| DCPX | H | - | - | - | 78 | 78 | 82 | 82 |
| | HL | standard | standard | standard | standard | standard | standard | standard |
| | HA | 78 | 80 | 82 | 82 | 82 | 82 | 82 |
| | HE | standard | standard | standard | standard | standard | standard | standard |
| GP | H - HL | - | - | - | 350 x 2 | 350 x 2 | 500 x 2 | 500 x 2 |
| | HA - HE | 260 x 2 | 260 350 | 350 x 2 | 350 x 2 | 350 x 2 | 500 x 2 | 500 x 2 |
| RIF | H - HL | - | - | - | RIFNRL2800 | RIFNRL3000 | RIFNRL3300 | RIFNRL3600 |
| | HA - HE | RIFNRL2000 | RIFNRL2250 | RIFNRL2500 | RIFNRL2800 | RIFNRL3000 | RIFNRL3300 | RIFNRL3600 |
| PRM1/PRM2 | Tutte | ✓ | ✓ | ✓ | ✓ | ✓ | ✓ | ✓ |

Choice of Unit

By suitably combining the numerous options available, it is possible to configure each model in such a way as to meet the most particular of system requirements.

Field configurator:

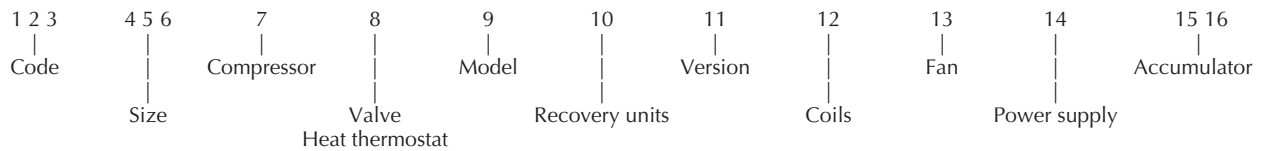

Code:

NRL

Size:

200, 225, 250, 280, 300, 330, 360

Compressors:

0 - R410A standard compressors

Thermostatic valve:

- ° - Standard mechanical thermostatic valve up to +4°C
- X - Electronic thermostatic valve also for low water temperature (down to -6°C)

Model:

H - Heat pump

Heat recovery units

- ° - Without recovery units
- D - With partial recovery (desuperheater)
- T - With total heat recovery

Version:

- H - Standard compact heat pump
- HL - Compact heat pump, silenced version
- HA - High efficiency heat pump
- HE - High-efficiency heat pump, silenced version

Coils:

- ° - Aluminium
- R - Copper
- S - Tinned copper
- V - Varnished

Fans:

- ° - Standard
- M - Enlarged
- J - Inverter

Warning:

- the standard options are shown by the symbol °;
- the XD and XT configurations are not available (for temperatures below 4°C only).

Example of the commercial code: **NRL200°H°E°°°04**

This is a size 200 NRL unit with aluminium condensing coils, PED standard evaporator, electrical panel for compressors with 400V 3~ 50Hz motors and with high-head accumulator and reserve pump.

As you may have noticed, each option is represented in a unique way from all the others, so it is not necessary to indicate (within the commercial code) the standard options (identified by °).

Power supply:

- ° - 400V 3~ 50Hz with thermomagnetic switches
- 2 - 500V 3~ 50Hz with thermomagnetic switches (contact the company head office for versions with DCPX).

Accumulator:

- 00 - without accumulator
- 01 - low-head accumulator and single pump
- 02 - low-head accumulator and reserve pump
- 03 - high-head accumulator and single pump
- 04 - high-head accumulator and reserve pump
- 05 - accumulator (with holes for supplementary electric heaters) low-head and single pump
- 06 - accumulator (with holes for supplementary electric heaters) low-head and reserve pump
- 07 - accumulator (with holes for supplementary electric heaters) high-head and single pump
- 08 - accumulator (with holes for supplementary electric heaters) high-head and reserve pump
- 09 - double hydraulic ring
- 10 - double hydraulic ring with supplementary electric heater
- P1 - without accumulator, with low-head pump
- P2 - without accumulator, with low-head pump and reserve pump
- P3 - without accumulator, with high-head pump
- P4 - without accumulator, with high-head pump and reserve pump

Technical data

| Mod. NRL | Vers. | 2000 | 2250 | 2500 | 2800 | 3000 | 3300 | 3600 | |
|---------------------------------|--------|---------|--------|---------|-----------------|-----------|--------|--------|--------|
| Cooling capacity | (kW) | H | | | 666 | 734 | 846 | 908 | |
| | | HL | | | 604 | 664 | 746 | 794 | |
| | | HA | 522 | 576 | 630 | 702 | 776 | 874 | 944 |
| | | HE | 462 | 515 | 568 | 638 | 710 | 796 | 852 |
| Total power input | (kW) | H | | | 280 | 318 | 332 | 358 | |
| | | HL | | | 308 | 348 | 374 | 408 | |
| | | HA | 188 | 203 | 218 | 252 | 286 | 302 | 324 |
| | | HE | 214 | 229 | 244 | 280 | 316 | 336 | 364 |
| Water flow rate | (l/h) | H | | | 114550 | 126250 | 145510 | 156180 | |
| | | HL | | | 103890 | 114210 | 128310 | 136570 | |
| | | HA | 89780 | 99070 | 108360 | 120740 | 133470 | 150330 | 162370 |
| | | HE | 79460 | 88580 | 97700 | 109740 | 122120 | 136910 | 146540 |
| Pressure drops | (kPa) | H | | | 40.2 | 40.4 | 46.9 | 45.7 | |
| | | HL | | | 33.4 | 33.6 | 37 | 35.5 | |
| | | HA | 53.5 | 61.4 | 61.4 | 48.0 | 48.6 | 54.0 | 53.5 |
| | | HE | 42.7 | 50.6 | 50.6 | 40.3 | 41.2 | 45.4 | 44.1 |
| EER | (W/W) | H | | | 2.38 | 2.31 | 2.54 | 2.54 | |
| | | HL | | | 1.96 | 1.90 | 1.99 | 1.95 | |
| | | HA | 2.78 | 2.84 | 2.89 | 2.79 | 2.71 | 2.89 | 2.91 |
| | | HE | 2.16 | 2.25 | 2.33 | 2.28 | 2.25 | 2.37 | 2.34 |
| ESEER | (W/W) | H | | | 3.57 | 3.50 | 3.53 | 3.60 | |
| | | HL | | | 3.47 | 3.43 | 3.44 | 3.41 | |
| | | HA | 3.96 | 4.04 | 4.13 | 3.91 | 3.82 | 3.85 | 3.82 |
| | | HE | 3.88 | 3.97 | 4.06 | 3.85 | 3.74 | 3.81 | 3.82 |
| Heating capacity | (kW) | H - HL | | | 768 | 854 | 936 | 1006 | |
| | | HA - HE | 586 | 637 | 688 | 776 | 866 | 968 | 1046 |
| Total power input | (kW) | H - HL | | | 252 | 282 | 310 | 332 | |
| | | HA - HE | 186 | 203 | 220 | 248 | 278 | 306 | 326 |
| Water flow rate | (l/h) | H - HL | | | 132100 | 146890 | 160990 | 173030 | |
| | | HA - HE | 100790 | 109560 | 118340 | 133470 | 148950 | 166500 | 179910 |
| Pressure drops | (kPa) | H - HL | | | 53.7 | 55.4 | 58.8 | 57.8 | |
| | | HA - HE | 68.8 | 75.5 | 75.5 | 58.2 | 60.1 | 66.3 | 65.9 |
| COP | (W/W) | H - HL | | | 3.05 | 3.03 | 3.02 | 3.03 | |
| | | HA - HE | 3.15 | 3.14 | 3.13 | 3.13 | 3.12 | 3.16 | 3.21 |
| Power supply | (A) | (All) | | | 400V - 3 - 50Hz | | | | |
| Type of fan | | | | | Axial | | | | |
| Total air flow rate | (m³/h) | H | | | 174800 | 173600 | 248400 | 244800 | |
| | | HL | | | 131000 | 138800 | 173800 | 171400 | |
| | | HA | 167200 | 209600 | 252000 | 248400 | 244800 | 336000 | 331200 |
| | | HE | 121200 | 148800 | 176400 | 180000 | 183600 | 235200 | 231800 |
| Total input current fan group | (A) | H - HL | | | 28.8 | 28.8 | 43.2 | 43.2 | |
| | | HA - HE | 28.8 | 36.0 | 43.2 | 43.2 | 43.2 | 57.6 | 57.6 |
| Maximum current (FLA) | (A) | H - HL | | | 588 | 646 | 730 | 796 | |
| | | HA - HE | 442 | 495 | 548 | 606 | 664 | 747 | 813 |
| Starting current (LRA) | (A) | H - HL | | | 797 | 855 | 998 | 1064 | |
| | | HA - HE | 651 | 763 | 816 | 815 | 873 | 1015 | 1081 |
| Type | | | | | Scroll | | | | |
| Compressors no. circuit | (no.) | All | 8/4 | 8/4 | 8/4 | 10/4 | 12/4 | 12/4 | 12/4 |
| Evaporator | | All | | | | Plates | | | |
| Type of plumbing connections | | All | | | | Victaulic | | | |
| Number of plumbing connections | | | 2 | 2 | 2 | 2 | 2 | 2 | 2 |
| Plumbing connections | (Ø) | H - HL | | | 4" | 4" | 4" | 4" | |
| | | HA - HE | 4" | 3"/4" | 4" | 4" | 4" | 4" | 4" |
| Tank capacity | (l) | All | 2x700 | 2x700 | 2x700 | 2x700 | 2x700 | 2x700 | 2x700 |
| Input power low-head pump | (kW) | All | 7.4 | 3.7+4.8 | 9.6 | 9.6 | 13.0 | 13.0 | 13.0 |
| Input power high-head pump | (kW) | All | 13.0 | 6.5+8.6 | 17.2 | 17.2 | 17.2 | 24.7 | 24.7 |
| Input current low-head | (A) | H/HL | | | 16.3 | 22 | 22 | 22 | |
| | | HA/HE | 12.4 | 6.2+8.1 | 16.2 | 16.3 | 16.3 | 22.0 | 22.0 |
| Input current high-head | (A) | H/HL | | | 29.2 | 29.2 | 42.4 | 42.4 | |
| | | HA/HE | 22.0 | 11+14.6 | 29.2 | 29.2 | 29.2 | 42.4 | 42.4 |
| Useful pump head low-head (**) | (kPa) | H | | | 149 | 142 | 122 | 115 | |
| | | HL | | | 167 | 157 | 145 | 141 | |
| | | HA | 111 | 128 | 128 | 128 | 125 | 106 | 95 |
| | | HE | 131 | 150 | 150 | 149 | 141 | 126 | 119 |
| Useful pump head high-head (**) | (kPa) | H | | | 290 | 274 | 257 | 251 | |
| | | HL | | | 310 | 297 | 280 | 276 | |
| | | HA | 225 | 269 | 269 | 266 | 246 | 241 | 232 |
| | | HE | 247 | 293 | 293 | 289 | 272 | 261 | 255 |
| Sound power | (dBA) | H | | | 93.5 | 93.5 | 95.0 | 95.0 | |
| | | HL | | | 90.5 | 90.5 | 92.0 | 92.0 | |
| | | HA | 91.5 | 93.3 | 94.5 | 94.0 | 93.5 | 95.0 | 97.0 |
| | | HE | 86.0 | 87.8 | 89.0 | 88.5 | 88.0 | 89.5 | 91.5 |

| Mod. NRL | Vers. | 2000 | 2250 | 2500 | 2800 | 3000 | 3300 | 3600 |
|----------------|-------|------|------|------|------|------|------|------|
| Sound pressure | H | | | | 62 | 61.5 | 63.0 | 65.0 |
| | HL | | | | 59 | 58.5 | 60.0 | 62.0 |
| | HA | 59.5 | 61.3 | 62.5 | 62 | 61.5 | 63.0 | 65.0 |
| | HE | 54.0 | 55.8 | 57.0 | 56.5 | 56.0 | 57.5 | 59.5 |

** The useful head is calculated in the cooling mode

Performance values refer to the following conditions:

■ Cooling:

- water outlet temperature 7 °C
- outside air temp. 35 °C
- $\Delta t = 5$ °C.

■ Heating:

- water outlet temperature 45 °C
- outside air temp 7 °C D.B. 6 °C W.B.;
- $\Delta t = 5$ °C.

♪ Sound pressure measured in free field conditions, in cooling mode, at distance of 10m and direction factor = 2. In accordance with the ISO 3744 standard

- Power supply voltage: 400 V

Dimensions (mm)

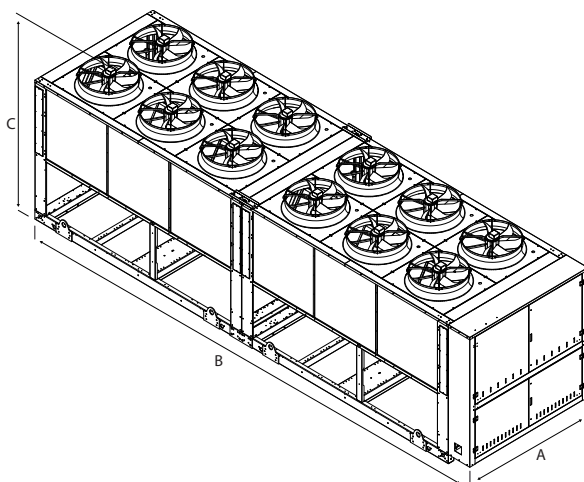

| Mod. NRL | Vers. | 200 | 225 | 250 | 280 | 300 | 330 | 360 | |
|-------------------|--------|---------|------|------|------|------|------|-------|-------|
| Height | (mm) C | H - HL | - | - | - | 2450 | 2450 | 2450 | 2450 |
| | | HA - HE | 2450 | 2450 | 2450 | 2450 | 2450 | 2450 | 2450 |
| Width | (mm) A | H - HL | - | - | - | 2200 | 2200 | 2200 | 2200 |
| | | HA - HE | 2200 | 2200 | 2200 | 2200 | 2200 | 2200 | 2200 |
| Depth | (mm) B | H - HL | - | - | - | 8100 | 8100 | 8100 | 8100 |
| | | HA - HE | 6400 | 7250 | 8100 | 8100 | 8100 | 11100 | 11100 |
| Weight when empty | (kg) | H - HL | - | - | - | 6080 | 6490 | 6660 | 6880 |
| | | HA - HE | 4930 | 5360 | 5780 | 6190 | 6630 | 7710 | 7980 |