

IDROSPLIT

Independent air conditioning and heating system
With capacities from 3.6 to 6.3 kW



R407C

The IDROSPLIT® module and the condensing unit together make up a low power consumption water chiller that offers a sufficient water flow to supply several terminal units.

The thermal head across the evaporator can be restricted to just 2.5°C.

Users can activate only a selected number of installed fan coils to regulate room conditions without having to exclude any sections of the water circuit. These appliances form the core of an air conditioning and heating solution that is particularly suitable for homes in both new construction and modernisation projects: the IDROSPLIT® system.

Features

- Appealing and functional styling
- Fully electronic adjustment and control with microprocessor card
- Prearranged for connection to a boiler with immediate summer/winter changeover
- Option of installing an air-cooled outdoor condenser unit (CX series) or an extremely quiet indoor water-cooled type (CWX series)
- equipped with a high efficiency rotary compressor
- Water can be supplied to all fan coils in the circuit so that the occupants in each room can choose whether or not to switch on individual units
- Water circuit complete with three-way valve, accumulation tank, expansion tank, safety valve, flow switch, circulator pump
- Electrical power requirements compatible with normal domestic supplies
- Extreme ease of installation
- Refrigerant lines up to 10 m in length (15 m for version CX/CWX 2667)

Accessories

- **DCPX:** Low temperature device for operation of outdoor units below 19 °C.
- **DM:** Assembly template.
- **RID:** Water connections for subsequent installation of Idrosplit module.

	Compatibility of accessories						
	ID	CX	CX	CX	CWX	CWX	CWX
	51	1667	2667	2667 T	1667	2667	2667 T
DCPX 25		✓	✓	✓			
DM	✓						
RID	✓						

Technical data

Mod.			ID 51	ID 51	ID 51	ID 51
			CWX 1667	CX 1667	CWX 2667	CX 2667
			CWX 2667 T		CX 2667 T	
Cooling capacity		kW	3.6	3.6	6.8	6.3
Total input power	230 V	kW	1.4	1.5	2.7	2.95
	400 V (mod. T)	kW	-	-	2.6	2.85
Evaporator water flow rate	nominal	l/h	620	620	1.170	1.080
	maximum	l/h	2.060	2.060	2.060	2.060
Tank capacity		l	34	34	34	34
Effective pressure	at nominal flow rate	kPa	78	78	64	66
	at maximum flow rate	kPa	26	26	26	26
Water consumption at 16 °C		l/h	170	-	350	-
Water flow rate at 29 °C (water from cooling tower)		l/h	760	-	1.520	-
Condenser pressure drops (water at 16 °C)		kPa	2.4	-	7.5	-
Condenser air flow rate		m ³ /h	-	1.460	-	2.430
♪ Sound pressure (CX - CWX)		dB (A)	29	30	34	34
Input current	230 V	A	6.5	7.1	13.1	14.7
	400 V (mod. T)	A	-	-	4.6	5.1
Peak current	230 V	A	33.5	33.5	74	74
	400 V (mod. T)	A	-	-	28	28

Power supply = 1~ 230V 50Hz; 3N~ 400V 50Hz (CX / CWX T).

Performance values refer to the following conditions:

- ♪ Sound pressure measured in free field conditions, with frontal distance of 10 m and direction factor 2.

■ Cooling:

- evaporator water outlet temperature 7 °C - Δt 5 °C;
- ambient air temperature 35 °C;
- condensing temperature 48 °C (CWX only).

Idrosplit system configurations

- 1 differential pressure switch
- 2 expansion tank
- 3 pump
- 4 accumulation tank
- 5 plate evaporator
- 6 quick-fit flare tube connections
- 7 three-way valve
- 8 safety valve and filling device
- 9 coplanar manifold
- 10 CX air conditioning unit (outdoor) or CWX water conditioning unit (indoor)
- 11 FCD - FCX - FCW fan coils (maximum 10)
- 12 condensate discharge
- 13 optional radiator

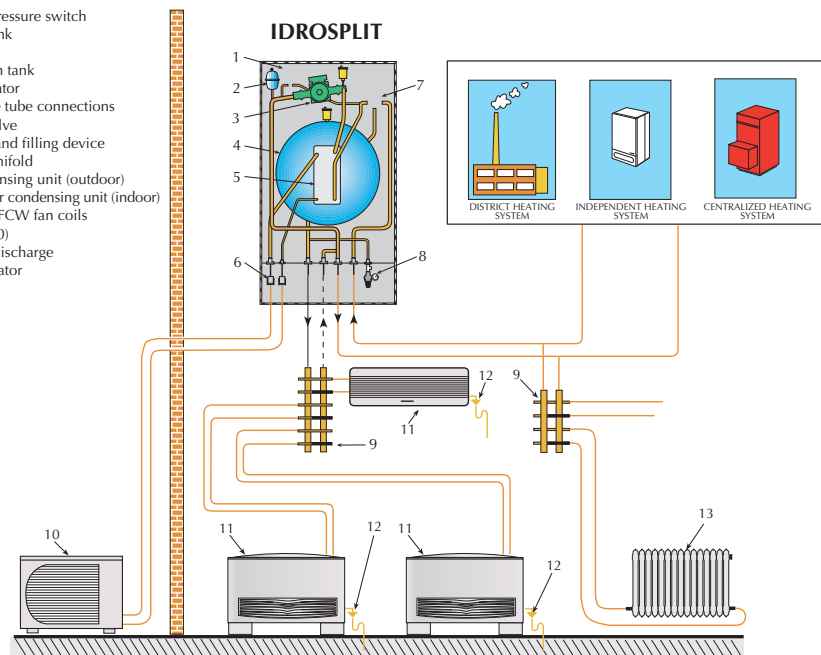

Dimensions (mm)

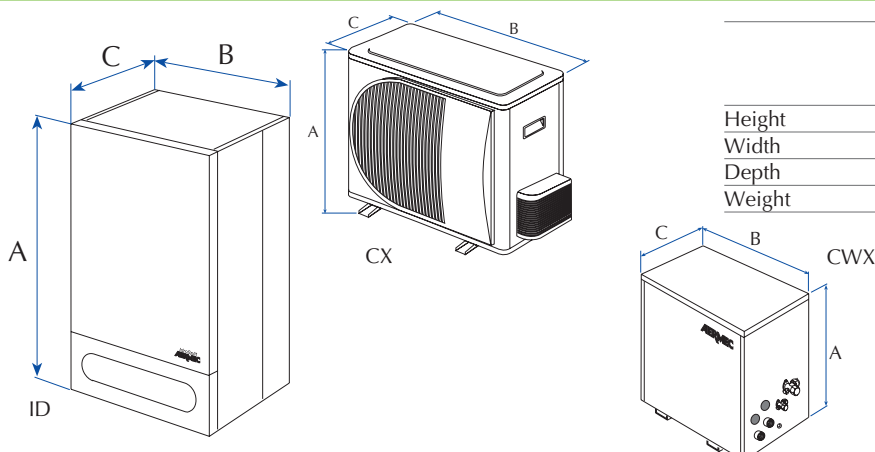

	ID	CWX	CX	CWX	CX
	51	1667	1667	2667	2667
2667 T 2667 T					
Height	A	850	450	530	570
Width	B	450	470	755	470
Depth	C	369	260	265	260
Weight	kg	43	40	37	49

The technical data in this document are not binding. Aermec S.p.A. reserves the right to make whatever modifications it deems necessary to improve the product at any time.

Aermec S.p.A.
Via Roma, 44 - 37040 Bevilacqua (VR) - Italy
Tel. +39 04 42 63 31 11 - Telefax +39 044 29 35 66
www.aermec.com