

Flexit SL4 R

Air Handling Unit with
rotating recovery system
– Energy-efficient
– New control system



NEW!
Patent applied for!

- Simple settings
- Flexible installation
- User friendly



FOR HEALTHY INDOOR AIR QUALITY

Flexit SL4 R

air handling unit with rotor technology

- Energy-efficient
- Flexible installation
- User friendly



Flexit's new ventilation unit has a number of important product advantages and meets the new stricter energy efficiency requirements being introduced in various European countries. The unit has a unique design (patent applied for) which gives great flexibility of installation in terms of positioning of ducts and location of the unit.

Flexit SL4 R has a rotating recovery system that ensures high recovery and simple installation.

The unit is compact and has small physical dimensions (height 700 mm, width 598 mm and depth 450 mm). Flexit SL4 R is suitable for detached houses, smaller homes and flats and smaller offices. The unit can be connected to an external cooker hood.

Energy savings and efficiency

A balanced ventilation unit with rotating recovery system lowers the cost of heating up ventilation air by up to 80% compared to an extract unit.

Example of savings in an ordinary semi-bungalow:

Heating requirement with central extraction:
approx. 10,600 kWh per year.

Heating requirement with balanced ventilation with 80% heat recovery: approx. 2120 kWh per year.

Saving: **8480 kWh** per year, multiplied by energy cost for heating.

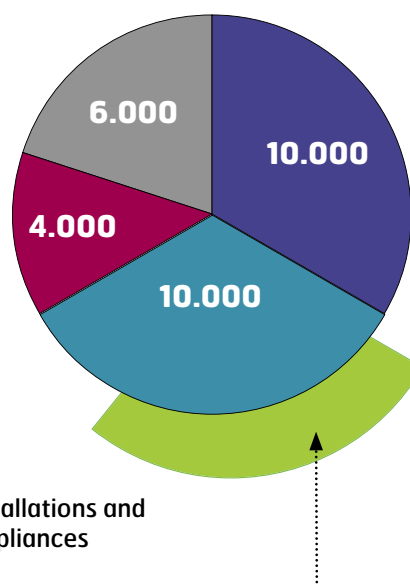

With a balanced ventilation unit with heat recovery you save up to **80%** of the cost of heating the ventilation air compared to an extraction unit.

Optimum ventilation with Flexit SL4 R

Clean, fresh air – all year round

The rotor unit offers stable operation throughout the year. The rotor technology copes effortlessly with icing and refreezing. This is particularly important in the Nordic countries with their cold climatic conditions.

High efficiency – energy savings

The rotor unit has a high efficiency and recovers up to 80% of the heat from the air extracted from the home. The high efficiency ensures that a high proportion of the energy used for heating the ventilation air is recovered while still providing the desired ventilation in the home – even in the cold season.

Energy consumption

Flexit SL4 R can be supplied with standard fans (AC) and low-energy fans (EC fans). EC fans have extra low energy consumption and ensure that the units are in readiness for future strict energy consumption requirements which will particularly focus on SFP (Specific Fan Power). The SFP value informs how efficiently a fan is able to transport the air.

Extra heating required only in severe cold

The rotor unit has a high efficiency and meets all the heating requirements for the ventilation air for most of the year. The heating batteries are dimensioned to cover heating requirements for ventilation air all year round, even when outside temperatures are very low. There is a choice between electric or water-based supplementary heating. For units with water-based supplementary heating, a water battery is provided for external installation in the duct.

Automatic summer operation

The rotor unit has an electronic control that automatically switches the recovery function off/on in accordance with the outside temperature. This gives much simpler operation than, say, a plate heat exchanger, which involves use of a summer cassette.

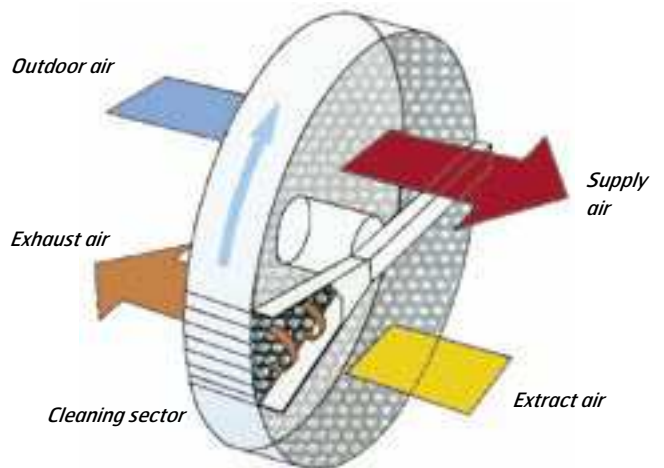

Basic sketch of rotor operation

Heat from the extract air passes through the rotor material to the supply air feeding the home. To prevent contaminated air entering the supply air, the rotor has a cleaning sector.

Simpler installation without a drainage outlet

The rotor technology does not require condensation drainage. The moisture in the extract air follows the air out of the house in the exhaust duct. As there is no need for a drainage outlet, this means simpler installation and lower installation costs, plus great freedom when it comes to locating the unit.

Area of use

The unit is particularly well suited to flats and small detached houses. The unit can be located in many different areas, for example in an outhouse, utility room, passage or loft. The unit can be installed vertically as a cabinet model or horizontally, for example in a loft.



Designed for modern homes

Flexit SL4 R is in white lacquer with rounded front door. The unit has been constructed for installation in a utility room, outhouse, technical room or loft.

Flexible installation

The design of the unit permits many different variations of duct arrangement or locations in a home. The unit is designed for installation in utility rooms, outhouses, lofts or other suitable rooms. The unit can be supplied in left or right versions (exhaust nozzle to the left or right) depending on what is most convenient for duct location. The advantage of rotor technology is that no condensation water is formed and connection to a drainage outlet is unnecessary. In wet rooms the unit must be located in zone 3 (minimum 0.6m from the edge of the bath and 1.2m from the shower head).

Wall installation as a cabinet model

Flexit SL4 R is ideal for wall installation as a cabinet model. For example the unit can be mounted in a wet room over a hot water heater or in conjunction with a wall cupboard. (Fig. 1).

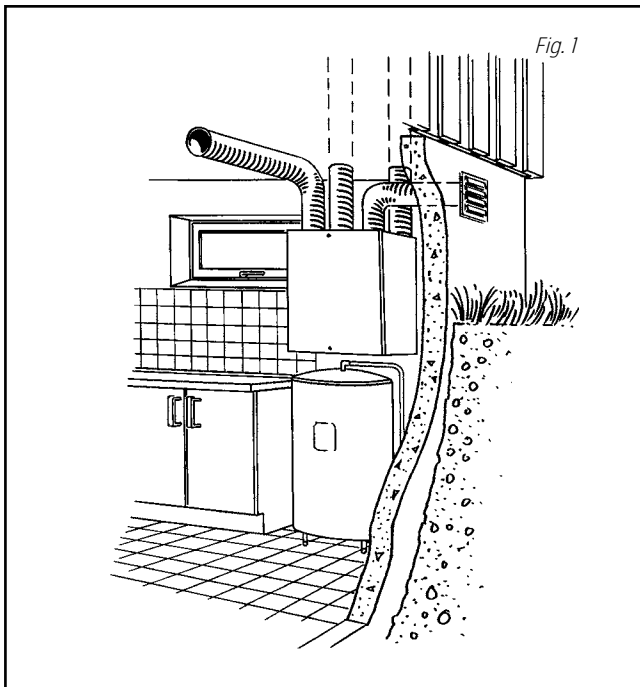

Loft installation

Flexit SL4 R has a chassis insulated for condensation and heat loss, which means that it can be installed in cold lofts. (Figs. 2a and b)

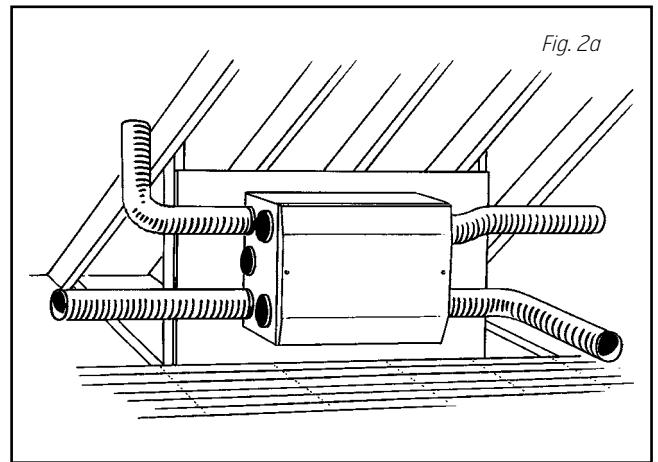

NB Mounting according to fig. 2a requires adjusting the nailing strip for hanging (see installation instructions).

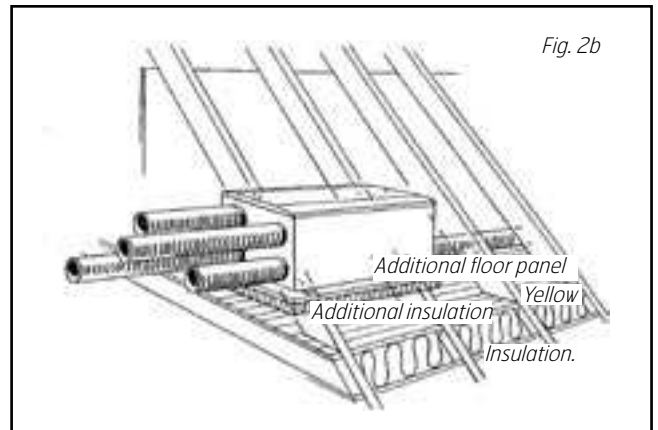

Mounting according to fig. 2b requires the use of the prescribed underlay (see installation instructions) to avoid vibration noise.

Flexible duct connection

The duct connections can be installed in different combinations, depending on what is most suitable in relation to the building:

- Traditional top connection of ducts (Fig. 1, page 5).
- Outdoor air and extract air ducts on one side and supply air and exhaust air ducts on the other side (Fig. 3)
- All duct connections on one side of the unit (Fig. 4)
- The extract duct can be connected to both of the short sides in the case of shorter ducts (Fig. 5).
- All duct connections on one side of the unit plus an extra extract duct on the other side (Fig. 5).
- Extract air, supply air and exhaust air ducts on one side and outdoor air on the other side of the unit (Fig. 6)
- The outdoor air duct and the extract duct can if desired easily be joined to one of the short sides of the unit (top and bottom).

External connection of a kitchen hood

The unit can be connected to an external kitchen hood. A separate duct connection provided as standard on the unit is used for the external kitchen hood. During cooking, the extract air is led from the cooker hood round the rotary heat exchanger. The cooker hood is supplied separately and is installed on site. There is a choice between slimline models, built-in hoods and ventilator cabinet models. Ask for information on our cooker hoods.

The Building Regulations recommend permanent ventilation in the kitchen. The appropriate ventilator should be located in the ceiling or wall. The louvres in the cookerhood must close when not in use.

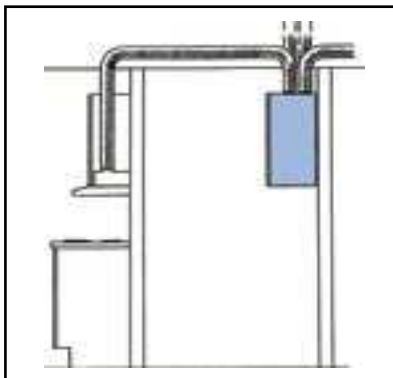

External connection of cooker hood

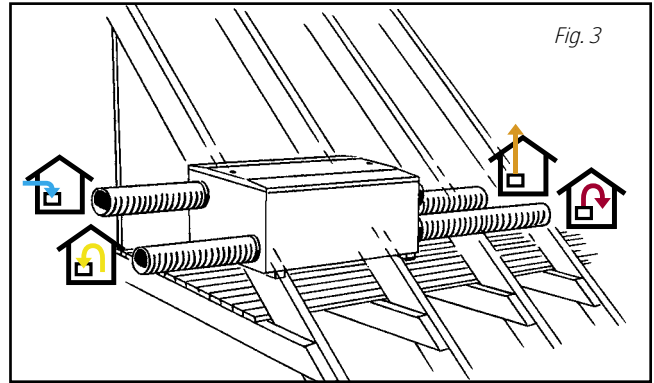

Fig. 3

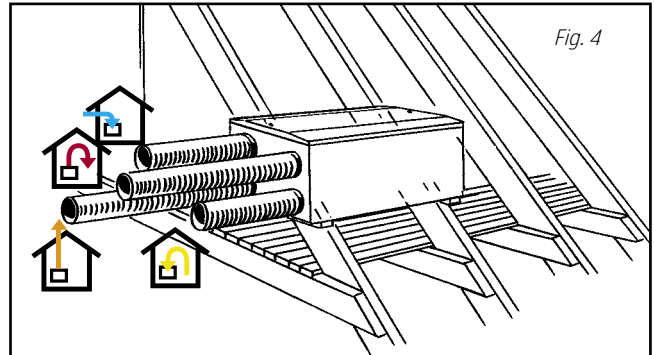

Fig. 4

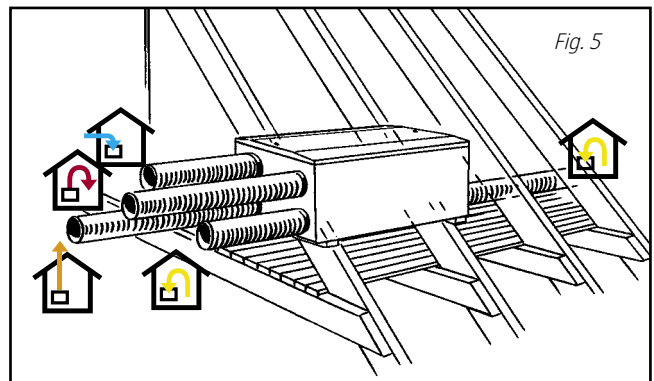

Fig. 5

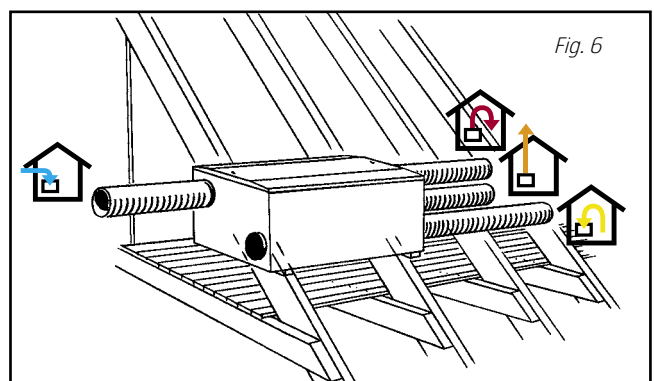

Fig. 6

Explanation of symbols



Product Description



Flexit SL4 R with rotating recovery system.

System description

The unit is designed to provide optimal air comfort combined with low energy consumption in the home. The heated used indoor air is sucked out via the extract valves in the kitchen and wet room, then passes through a filter and is fed into the unit's rotary heat exchanger, after which it is expelled from the house via a roof hat or wall outlet (combibox). The outdoor air is introduced into the unit via an outdoor air intake, is filtered, continues through a rotary heat exchanger where it takes on the heat from the extract air. The electronically controlled supplementary heating battery ensures a comfortable supply air temperature in the event of especially cold weather. After passing through the unit, the supply air normally flows through sound absorbers before entering the home through the supply air valves – fresh, clean and at the appropriate temperature. Flexit SL4 R has an electronic control system which is run from a separately mounted control switch, CI 50.

Rotating recovery system

Flexit SL4 R has an efficient rotating recovery system. To guard against air flows contaminating each other the recovery system is fitted with a cleaning sector. In addition both the exhaust air and the supply air are filtered so no contamination will come into contact with the rotor materials.

Basic settings

The unit has two basic setting switches, one for supply air and one for extract air. The unit can be set to 120, 150 or 170 Volts on both fans at normal speed. (Flexit SL4 R is supplied from the factory with a setting of 150 V. See "Ventilation data documentation" for the correct setting.) To achieve further adjustment ranges, it is necessary to switch over directly on the transformer.

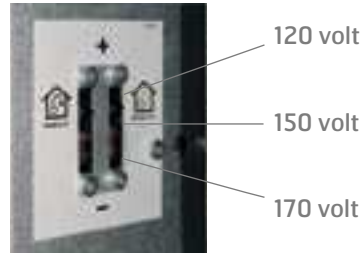

Installation

The rotor units do not create condensation water. This makes installation simpler, as no drainage outlet is required. Locating the unit is more flexible as no account needs to be taken of distance from the drain.

Design

The unit's outer cabinet is in white-lacquered sheet steel. The inner cabinet is in galvanised sheet steel with 15 mm of condensation insulation. The front door is in plastic to reduce weight and to facilitate inspection and service. The door is rounded in shape and opens/closes with press buttons.

Duct connections

The connection dimension is a 160 mm dia. nipple. This is a flexible solution as it includes moveable connecting pieces while blind flanges are used to seal the duct outlets not in use. These are locked with screws during installation (Fig. 7). The unit is available in right or left versions.

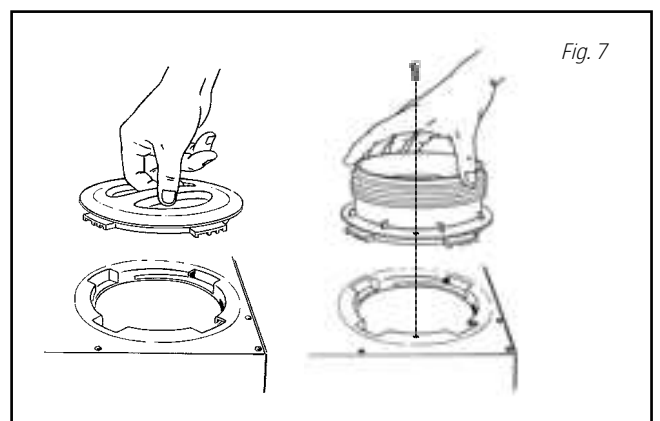

Temperature adjustment

The unit is supplied with an electronic temperature sensor which must be mounted in the supply air duct. The desired supply air temperature is set on the control panel and the temperature is maintained by the unit's rotating recovering system and supplementary heating battery.

Fans

Flexit SL4 R is fitted with single-suction F-wheel radial fans. The fans have a low noise level and a high capacity, even in the case of long ducts. The cover over the fan can be removed by pressing the catches on the lower edge. The fan can be removed from its track. The motor and fan blades are removed by unscrewing the 4 screws in the round motor plate and carefully pulling the motor out of the motor housing.

Heating element – electric or water-based

To ensure the supply air has the correct comfort temperature and does not feel like a cold draught, the units are fitted with an electronically controlled supplementary heating element or water-based-heating battery. This is switched on when the supply air temperature falls below the set level and produces the necessary temperature increase.

Summer operation

The rotating heat exchanger is electronically controlled and controls the supply air temperature. During the warm part of the year, the recovery function is switched off automatically when not required. A summer cassette is therefore not necessary.

Filters

The unit is fitted with supply air and extract air filters in the F7 class. The filters can be replaced easily without the use of tools.

The rotor unit requires regular filter replacement (1-2 times a year) to ensure clean, fresh air and problem-free operation.

Control

The Flexit SL4 R is fitted with electronics which control the unit automatically via a circuit board. A CI 50 control panel with a 12 m signal cable and ISDN plug for simple, flexible installation of the control panel is

supplied. The supply air temperature is maintained by means of the high-efficiency heat recovery system in the rotor. The rotor is controlled according to the required supply air temperature. If this cannot be maintained by the rotor alone, the supplementary heating battery automatically cuts in as required. In the warm part of the year, when heating requirements are minimal, the rotor stops, thus avoiding heating up the supply air.

Using the CI 50, the fans can be set to three speeds and the rotor/heating can be activated. The panel has pilot lamps showing the speed selected and whether the heating sequence has been activated. A lamp gives warning of fire/overheating and indicates when the filter should be changed.

Fan speeds

The desired speed is selected on the unit's control panel. CI 50 A forced air flow is obtained either by altering the pressure fall in the duct network by operating the extract ventilator with pull cord or similar, or by increasing the fan speed to maximum.

New control system

CI 50

The new Flexit SL4 R is also accompanied by a newly developed automatic control system - CS 50, which consists of the control panel CI 50 and the motherboard CU 50. The control panel has a modern design for wall mounting. It is easy to control the unit from the panel, using clearly marked push buttons. Air flow and forced air ventilation, for example when taking a shower, and the desired air changes can all be controlled from the panel. The desired supplementary heating can be adjusted, and a lamp will light when the heating is on. A lamp will also light when the filter needs changing.

Position 2 is for normal operating ventilation. This is the position for daily operation. Position 1 is used when not as much ventilation as normal is required. Position 3 is used when there is a need for extra ventilation in wet rooms or the whole house, and is used during and for a while after showering, for example, or clothes drying.

As standard, the CI 50 is supplied for flush wall mounting. **In this case a double Elko-type wall box must be used.** A surface mounted wall box to take the control panel can be supplied as an accessory.

An extra forced air/control switch, CI 50, for installation near a shower, for example, can be supplied as additional equipment.



CI 500

A separate control panel, CI 500, is available with timer function for automatic timed control of the unit. See list under "Accessories".

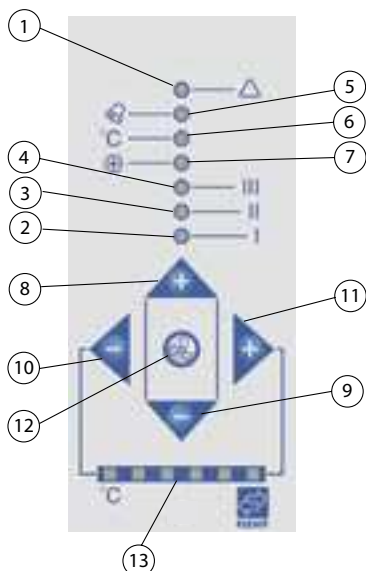

1. Indicator, alarm
2. Indicator, speed 1
3. Indicator, speed 2
4. Indicator, speed 3
5. Indicator, filter change
6. Indicator, supplementary heating activated (heating element)
7. Indicator, heating Off/On
8. Button, higher fan speed
9. Button, lower fan speed
10. Button, lower supply air temperature
11. Button, higher supply air temperature
12. Button, forced air
13. Indicator, shows set temperature from 15 - 25 C

Accessories

Art. no.	Type
12336	Filter set, F7
09380	Additional forced air/control switch
13750	Brasserie-E white
13751	Brasserie-E steel
13616	Fondu-E Slimline
13626	Bistro-E, built-in cooker hood
	External water battery with control system
	Surface-mounted box
	CI 500, control panel with timer function



Filter set (F7) for extract and supply air



Extra forced air and control switch



Control panel, CI 500

Cooker hoods for external connection



Brasserie-E white



Fondu-E



Brasserie-E, steel



Bistro-E

Flexit SL4 R

Art.no.	Type
14020	SL4 REL AC left mod with electric battery and AC fan
14021	SL4 RER AC right mod with electric battery and AC fan
14022	SL4 RWL AC left mod with water battery and AC fan
14023	SL4 RWR AC right mod with electric battery and AC fan
14024	SL4 REL EC left mod with electric battery and EC fan
14025	SL4 RER EC right mod with electric battery and EC fan
14026	SL4 RWL EC left mod with water battery and EC fan
14027	SL4 RWR EC right mod with water battery and AC fan



Technical data

	SL4 RE	SL4 RE EC	SL4 RW	SL4 RW EC
Rated voltage:	230 V/50 Hz	230 V/50 Hz	230 V/50 Hz	230 V/50 Hz
Fuse:	10 A	10 A	10 A	10 A
Rated current, total:	5.4 A	4.4 A	1.5 A	0.5 A
Rated power, total:	1235 W	1005 W	335 W	105 W
Rated power, electric battery:	900 W	900 W	-	-
Rated power, fans:	2 x 165 W	2 x 50 W	2 x 165 W	2 x 50 W
Fan type:	F-wheel	F-wheel	F-wheel	F-wheel
Fan motor control:	Transformer	Transformer	Transformer	Transformer
Max. fan speed:	2230 rpm	1800 rpm	2230 rpm	1800 rpm
Automatic control standard:	CS50	CS50	CS50	CS50
Filter type (SUP/EXTR):	F 7/F 7	F 7/F 7	F 7/F 7	F 7/F 7
Filter dimensions Supply air (W x H x D):	350x185x50 mm	350x185x50 mm	350x185x50 mm	350x185x50 mm
Filter dimensions Extract air (W x H x D):	350x185x50 mm	350x185x50 mm	350x185x50 mm	350x185x50 mm
Weight:	47 kg	47kg	47 kg	47 kg
Duct connection:	Dia. 160 mm	Dia. 160 mm	Dia. 160 mm	Dia. 160 mm
Height:	700 mm	700 mm	700 mm	700 mm
Width:	598 mm	598 mm	598 mm	598 mm
Depth:	450 mm	450 mm	450 mm	450 mm

AC-fan: Normal speed set at factory to 150 V

EC-fan: Normal speed set at factory to 7 V

Symbols Used

This product has a number of symbols that are used to label the product itself and in the installation and

user documentation. Here is an explanation of some of the commonest symbols:



Flexit SL4 R, right mod

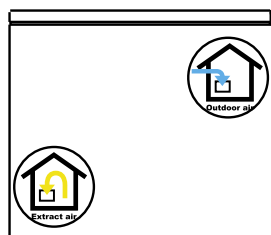
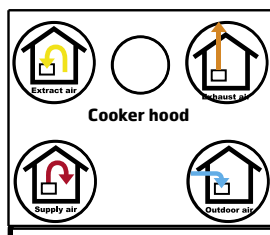

Flexit SL4 R, left mod

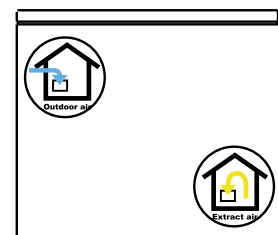
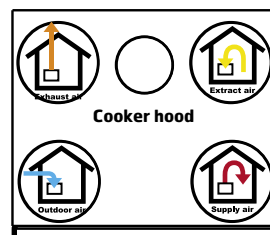

Our products are subject to continuous development and we therefore reserve the right to make changes. We also disclaim liability for any printing errors that may occur.

System sketch

Extract air Supply air Outdoor air Exhaust air

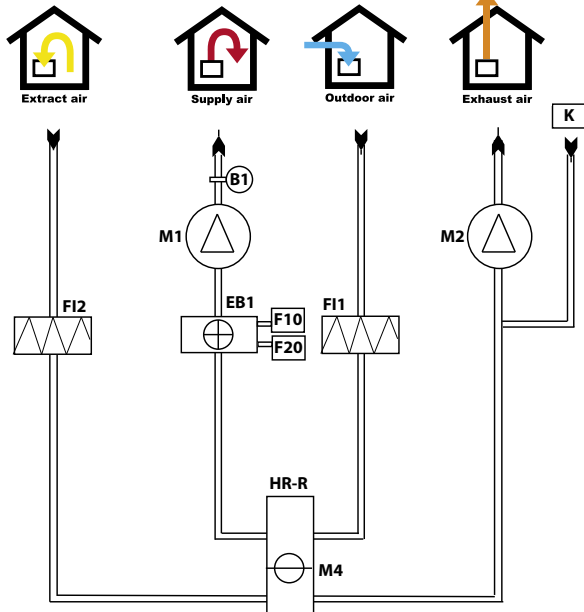

- B1 Supply air temperature sensor
- EB1 Heating element
- F10 Overheating thermostat, MANUAL RESET
- F20 Overheating thermostat, AUTOMATIC RESET
- F11 Supply air filter
- F12 Extract air filter
- M1 Supply air fan
- M2 Extract air fan
- HR-R Rotary wheel-type heat exchanger
- M4 Rotor motor
- K Cooker hood (accessory)

Dimensioned Drawing

Dimensions in mm

Shown as right version

THE LEFT MODEL IS INVERTED

Shown from below

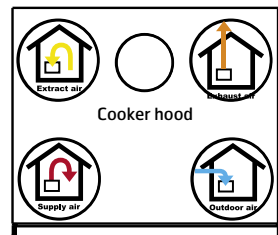
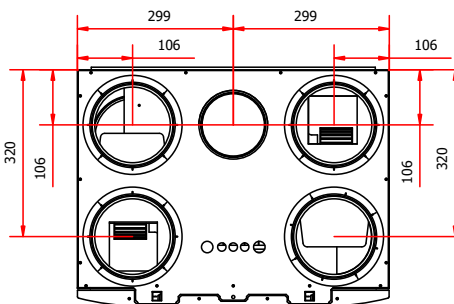
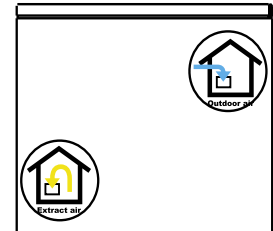
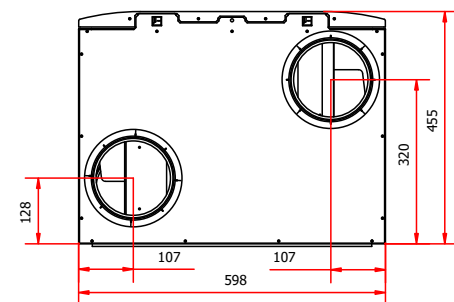
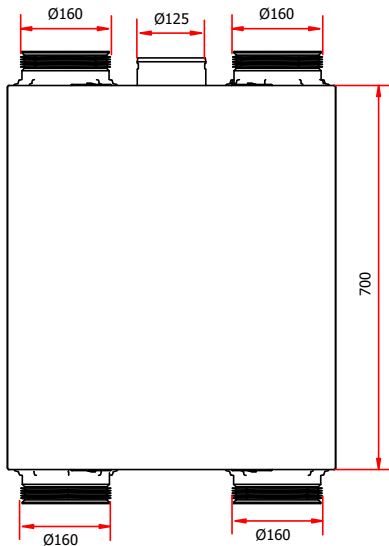

Shown from above

Front

Capacity diagram SL4 R W/E (AC-fan)

(measured with F7 filter)

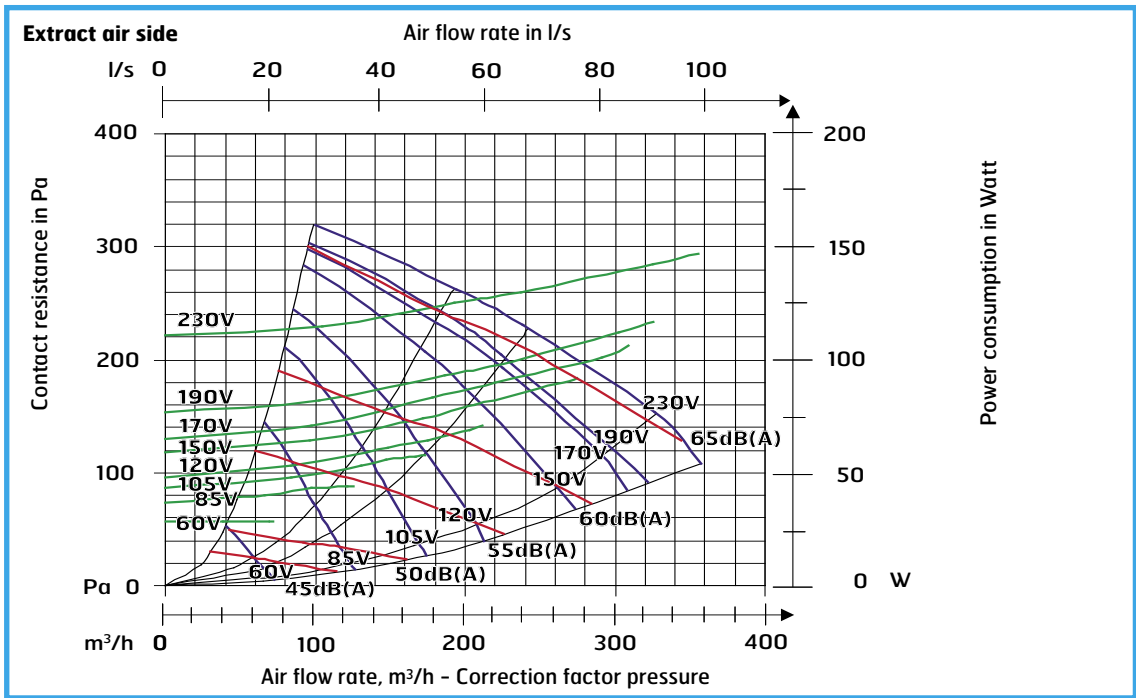
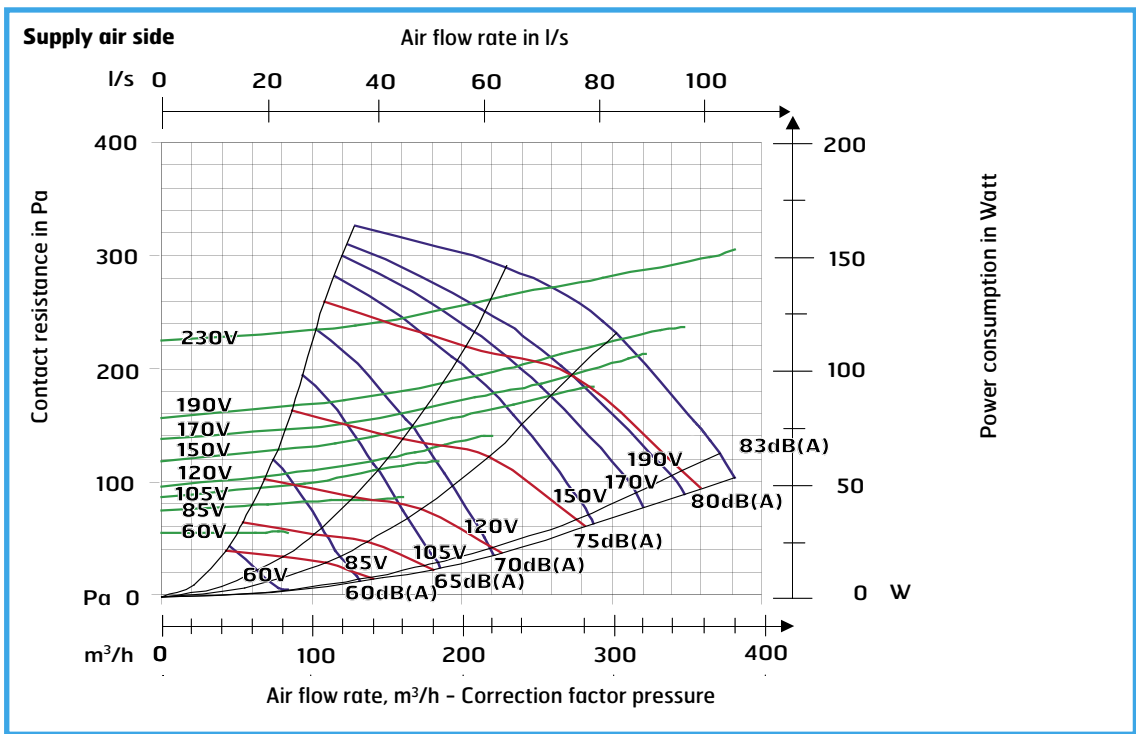

Sound Data is given at sound power level L_{wA} in the capacity diagrams and is corrected with the table below for the various octave bands and total L_w in the various octave bands and total L_{wA} . Radiated noise is calculated by taking the noise value from the supply air table and deducting the total value from the correction factor table.

Correction factors for L_w

Hz	63	125	250	500	1000	2000	4000	8000	L_{wA}
Supply air	3	1	2	-1	-7	-11	-18	-31	
Extract air	10	8	5	-2	-11	-19	-30	-48	
Radiated	-55	-43	-35	-36	-33	-31	-40	-50	-27,1

Temperature efficiency

Efficiency is expressed as component efficiency and unit efficiency.

Component efficiency (theoretical efficiency of rotor) is 83-85% at 250-200m³/h.

Unit efficiency (measured efficiency of whole unit, including losses and other factors) is approx. 75% at 200m³/h.

Capacity diagram SL4 R W/E (EC fan) (measured with F7 filter)

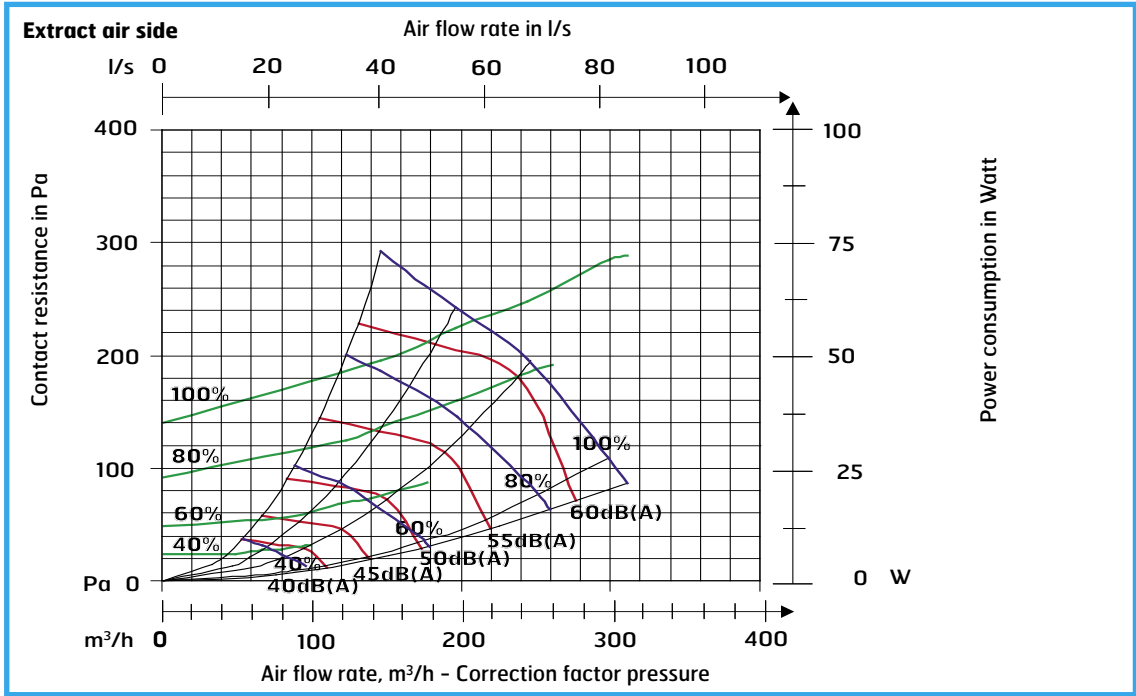
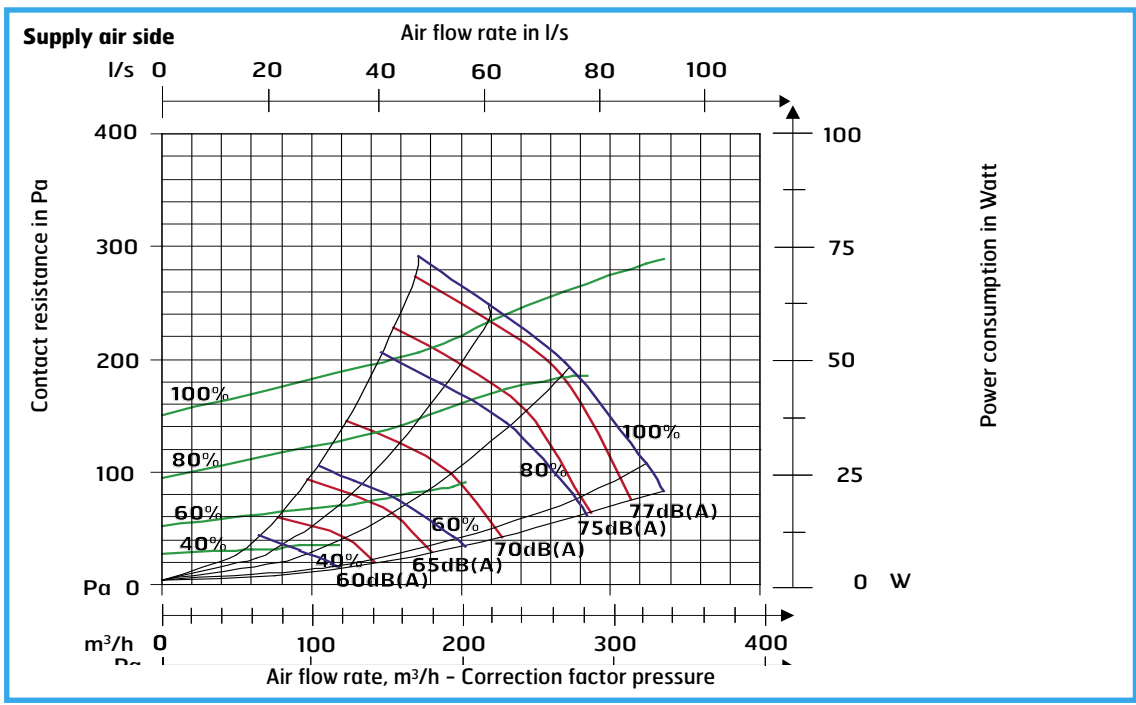

Sound Data is given at sound power level L_{wA} in the capacity diagrams and is corrected with the table below for the various octave bands. Radiated noise produces L_w in the various octave bands and total L_{wA} . Radiated noise is calculated by taking the noise value from the supply air table and deducting the total value from the correction factor table.

Correction factors for L_w

Hz	63	125	250	500	1000	2000	4000	8000	L_{wA}
Supply air	3	1	2	-1	-7	-11	-18	-31	
Extract air	10	8	5	-2	-11	-19	-30	-48	
Radiated	-55	-43	-35	-36	-33	-31	-40	-50	-27,1

Temperature efficiency

Efficiency is expressed as component efficiency and unit efficiency.

Component efficiency (theoretical efficiency of rotor) is 83-85% at 250-200m³/h.

Unit efficiency (measured efficiency of whole unit, including losses and other factors) is approx. 75% at 200m³/h.