



## General description

The ELITE series is the optimal solution to provide a pleasant indoor climate and a healthy environment in homes, offices and public buildings.

The importance of a good indoor climate has been brought into focus in recent years, not least because new buildings are very well insulated and are now nearly completely air tight. Cases of asthma and allergy attacks are increasing, primarily since the introduction of double glazing a couple of decades ago.

ELITE is a high-quality ventilation product providing a refreshing breeze of comfort to your home or workplace. Installation of an ELITE ventilation system not only purifies the air for pollen, dust and other damaging and harmful substances, it will also free your home from excessive moisture which is often the reason for steamed-up windows, bad smell and damages like mould and dry rot.

The ELITE ventilation system is easy to control. The control function is assured by a remote control unit that can be placed anywhere in the house.



## Capacity diagrams

### Elite 400

Air volume

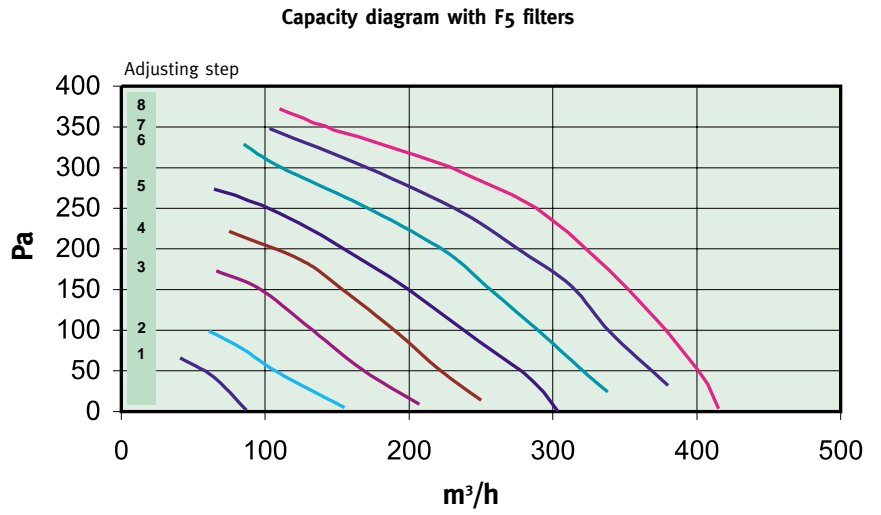

Temperature efficiencies

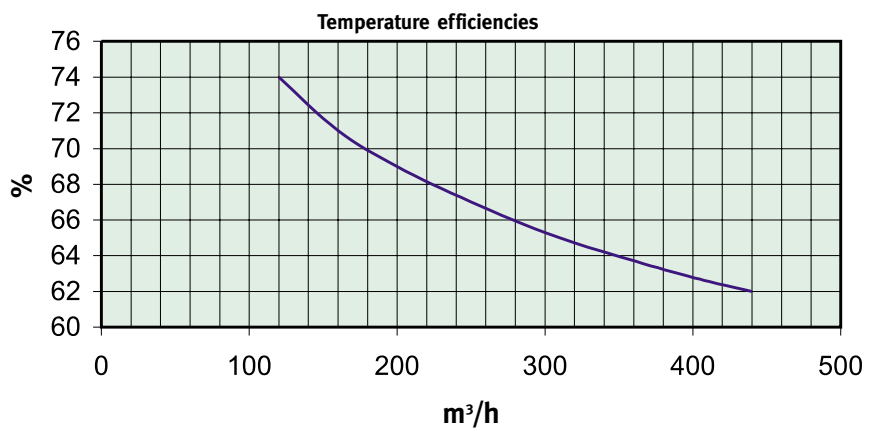



## Elite 800

Air volume

Capacity diagram with F5 filters

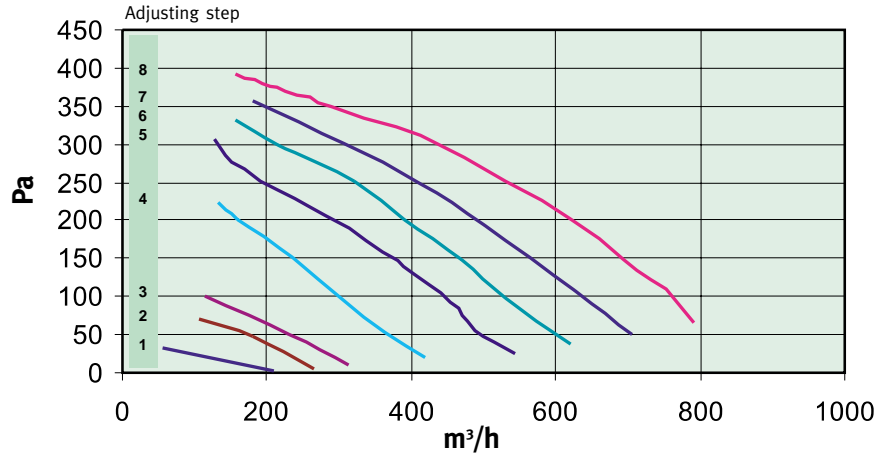

Temperature efficiencies

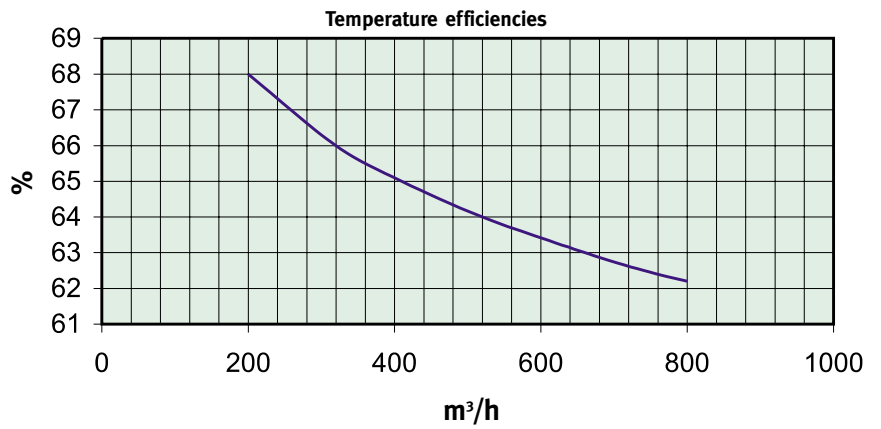



## Technical data

Model		Elite 400	Elite 800
Air volume	m <sup>3</sup> /h	400	800
Efficiency	%	73	68
Power supply	V/Hz	1x230/50	2x230/50
Max. power consumption	W	1780	2900
Max. current consumption	A	7,8	12,6
Electric heating element	W	1500	2400
Filters supply/exhaust air		F5/F5	F5/F5
Duct connection	Ø mm	160	200
Sound level at a distance of 1 m	dB(A)	48	51
Weight	kg	64	95
Dimensions (HxLxW)	mm	600x1000x400	750x1100x500

The ELITE cabinet is made of 50 mm double-skinned insulated hot-dipped galvanized panels and it has an upper and a lower access door on the inspection side.

To replace filter, open the upper access door.

To clean the exchanger, open both the upper and the lower access doors.

ELITE 400 is suitable for use in offices and private homes up to 200 m<sup>2</sup>.

ELITE 800 is suitable for use in public buildings, offices and larger homes up to 400.

mm	A	B	C	D	E	F	G	H	I
Elite 400	1000	400	600	160	200	152	205	243	240
Elite 800	1100	500	750	200	250	195	333	222	275

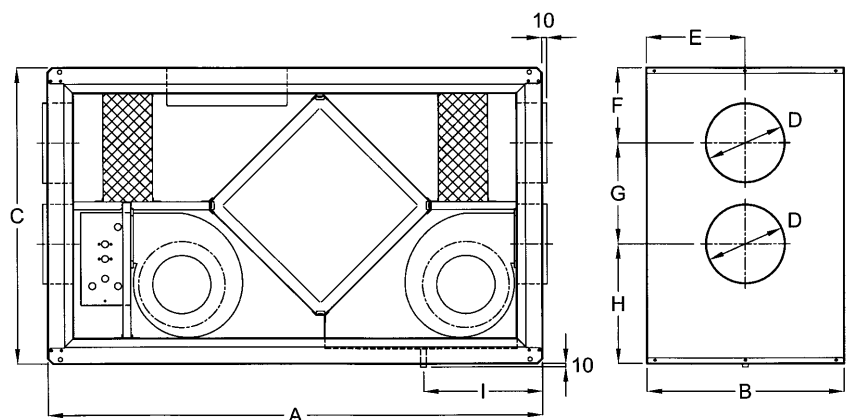



## Service and operation

The control unit is delivered together with the ventilation unit and it is very easy to operate. The entire operation can be carried out by means of one pushbutton, allowing selection of air volume.

By pressing the button quickly, the air volume is increased with one step at a time. If the push-button is held down for 5 seconds, it switches over to OFF.

A green light diode indicates which air volume has been chosen. LOW or MEDIUM are intended for normal running speeds, whereas HIGH is intended for quick air change.

In order to save energy, the control system automatically switches back to the initial setting two hours after it was set to HIGH. An extra three-coloured light diode indicates the actual running mode.

**Green light:** Plant is OK, ventilation running without heat.

**Yellow light:** Plant is OK, running, but heat is switched on.

**Red light:** Plant stopped because heating element is too hot.

**Info light flashes:** Filter has to be checked and perhaps replaced.

The time interval for the filter guards is 6 months.

To reset the time interval, keep down the button for 15 seconds.

### Summer operation

The ELITE control unit is able to distinguish between summer and winter. When the fresh air temperature is higher than 15°C, the control system will interpret this as summer and heat is switched off. This reduces the energy consumption during warm periods of the year.

### Frost protection

At extremely low fresh air temperatures, ventilation is automatically reduced, once it has been registered that the heating coil is not able to maintain the required temperature. This reduces energy consumption during cold periods of the year.

This function is not active in HIGH position, which is limited in time.

### Defrosting of the heat exchanger

If the temperature after the heat exchanger/exhaust air is under 5°C, there is a risk of ice formation on the heat exchanger. If so, ice formation will be allowed for one hour, after which the supply air fan and additional heat, if any, will be stopped for two minutes to let the heat exchanger be defrosted by return air.

The drawing below shows the principle of a ventilation plant with heat exchanger.

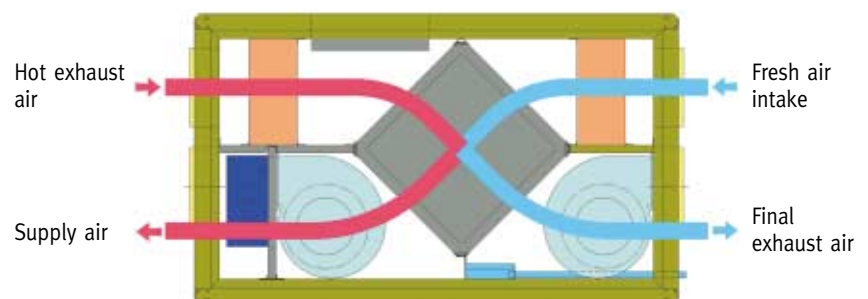



## Setting of air volume and temperature

By means of the purpose designed electronic control unit it is possible to match air volume and heat with a view to obtaining the highest possible comfort without exaggerated use of energy. By means of the 3-stage electric heating coil the electronic control can provide the required room temperature at any time. The temperature can be set between 17°C and 21°C. Therefore the ELITE unit is primarily intended as an air change plant and heating must be provided by other sources of heat.

The following air volumes can be selected: LOW - MEDIUM – HIGH. On LOW and MEDIUM there is a free choice between 7 speeds, making it possible to select the air volume that matches the requirements best. On position HIGH the plant is running at max. air volume.

The diagram below shows the setting of the air volume

Air volume	Setting of dipswitches			Voltage (Volt)	Power consumption for fans		
					(A)	(A)	
		1	2	3	Elite 400	Elite 800	
1	On				69	0,11	0,19
	Off						
2	On				92	0,20	0,35
	Off						
3	On				115	0,31	0,55
	Off						
4	On				138	0,45	0,81
	Off						
5	On				161	0,61	1,09
	Off						
6	On				184	0,78	1,40
	Off						
7	On				207	0,96	1,72
	Off						
8	On				230	1,13	2,03
	Off						

The diagram shows the settings of dipswitches 1-2-3.  
The same settings/values apply for dipswitches 4-5-6.

The dipswitches 1-2-3 control low speed (LOW SPEED)

The dipswitches control medium speed (MEDIUM SPEED)

(HIGH SPEED) = 230 V

As standard low fan speed is set at 1 and medium fan speed is set at 5.

As standard ELITE ventilation units are fitted with two heating elements, each with 3 steps.

**For Elite 400:** 500W - 1000W - 1500W.

**For Elite 800:** 800W - 1600W - 2400W.



The diagram below shows the setting of the supply air volume.

Supply air temperature	Setting of dipswitches	
		7 8
8°C*	On	<input type="checkbox"/>
	Off	<input checked="" type="checkbox"/>
17°C	On	<input checked="" type="checkbox"/>
	Off	<input type="checkbox"/>
19°C	On	<input checked="" type="checkbox"/>
	Off	<input type="checkbox"/>
21°C	On	<input checked="" type="checkbox"/>
	Off	<input type="checkbox"/>

The diagram above shows the combination possibilities for getting the most suitable temperature for the given situation.

The dipswitches 7 - 8 control the supply air temperature.

Standard temperature is pre-set at 21°C.

\*8°C is used as frost protection of the heating coil.  
(The heating coil is extra accessory).

As standard the unit is pre-set to keep a supply air temperature of 21°C. This means that the sensor in the supply airflow is active and controls the heat and the fan in order to keep a constant temperature of 21°C.

If the supply air temperature cannot be kept at 21°C, even if the heat is switched on at full load, then the fan speed is gradually lowered until the required temperature is reached. Once the fan speed is so low that the supply air temperature exceeds 21°C, the fan speed is gradually increased again by one step every minute. After that heat steps will be gradually lowered as long as the temperature remains at 21°C or more.



## Accessories

### Pollen filter - F9

Pollen filters are very effective when it comes to small particles such as dust, pollen and other harmful substances. Pollen filters are recommended in case of asthma and allergy tendencies.

### Fire thermostat

Protects against fire. The fire thermostat is set to f.inst. 40°C and is built into the exhaust air duct. Switches off the plant if the exhaust air temperature exceeds 40°C.

### Room thermostats for HEAT and COOL functions

With the HEAT function you can maintain a minimum temperature in a room. With the COOL function you can bring the temperature down to the required level.

### Water heating coil

Water heating coils 2RR are available as an alternative to the built in electric heating coils.

#### Water heating coil for Elite 400

Air output (m <sup>3</sup> /h)	Water in/out (°C)	Heat output (kW)	Air temp. in(°C)	Air temp. out(°C)	Water resistance KPA
200	80/60	2,6	5	41,0	0,9
200	70/50	2,1	5	34,7	0,6
200	70/40	1,8	5	29,9	0,2
200	60/40	1,7	5	28,5	0,4

#### Water heating coil for Elite 800

Air output (m <sup>3</sup> /h)	Water in/out (°C)	Heat output (kW)	Air temp. in(°C)	Air temp. out(°C)	Water resistance KPA
400	80/60	5,0	5	40,4	4,0
400	70/50	4,2	5	34,6	3,0
400	70/40	3,6	5	30,6	1,2
400	60/40	3,4	5	28,7	2,1

### Frost thermostat - Danfoss KP 75

For frost protection of the water heating coil when the plant is off.

#### System 1:

#### External thermostat for manual control of the supply air temperature

A capillary tube thermostat is available for manual control of the supply air temperature.

#### System 2:

#### External thermostat for automatic control of the supply air temperature

- Room thermostat (setting area 15-30°C) - (0-10V DC)
- Duct sensor
- Two-way valve - to be selected on basis of the K<sub>VS</sub> values below
- Valve actuator - (2-10V)
- Transformer - (220V / 24V AC / 10,5VA)

K<sub>VS</sub> values for selecting two-way valves:

	Elite 400	Elite 800
District heating	K <sub>VS</sub> 0,16	K <sub>VS</sub> 0,4
Boiler plant	K <sub>VS</sub> 0,4	K <sub>VS</sub> 0,63