

Cucciolo

Portable room air conditioners

R407C



Features

- Versions:
CMX 67: white cabinet
CMX 67S: white cabinet with quick couplings for disconnection of outdoor unit
- Portable room air conditioner with two sections linked by a flexible refrigerant line
- The indoor unit is wheel mounted for easy handling
- Sheet metal cabinet with anti-rust paint finish
- High efficiency rotary compressor
- Quiet operation
- Automatic condensate removal by means of patented Electronic Jet system
- Indoor unit with three speed fan and air deflectors with horizontal and vertical adjustment facilities
- Washable air filter
- Infrared remote handset with LCD display for full control of all appliance functions
- Local and remote control capability
- Microprocessor control
- Timer for programming On/Off times
- Programs for cooling only, heating only, dehumidification and automatic operation (heating/cooling)
- Filter maintenance LED
- Automatic reset following power loss

Accessories

- **AMB:** designed to attach the outdoor unit to a window ledge
- **RX:** Electric element: allows the indoor unit to work as a heater

Compatibility of accessories	
	CMX 67
AMB	✓
RX 54	✓

Technical data

Mod.			CMX 67	CMX 67 S
Cooling capacity		W	2400	2400
Moisture removed		l/h	1.1	1.1
Total input power		W	860	860
Input current		A	4.0	4.0
Heating capacity with electric heater		W	1200	1200
Input power with electric heater		W	1250	1250
Input current with electric heater		A	5.6	5.6
Indoor unit air flow rate	minimum	m ³ /h	230	230
	medium	m ³ /h	280	280
	maximum	m ³ /h	350	350
Indoor unit fan speed	minimum	rpm	705	705
	medium	rpm	840	840
	maximum	rpm	1005	1005
Outdoor unit air flow rate		m ³ /h	880	880
Outdoor unit fan speed		rpm	850	850
Peak current		A	19.5	19.5
Refrigerant			R 407C	R 407C
Refrigerant charge		kg	0.83	1.15
Refrigerant line length		m	2	2.8
♪ Sound pressure (indoor unit)	minimum	dB (A)	38.5	38.5
	medium	dB (A)	41	41
	maximum	dB (A)	42	42
♪ Sound pressure (outdoor unit)		dB (A)	41.5	41.5

Power supply = 1~ 230V 50Hz.

Performance values refer to the following conditions:

- ♪ Sound pressure was measured in an 85 m³ semi-reverberant test chamber with reverberation time Tr = 0.5s.

■ Cooling:

- room air temperature 27 °C D.B., 19 °C W.B.;
- ambient air temperature 35 °C; maximum speed.

Dimensions (mm)

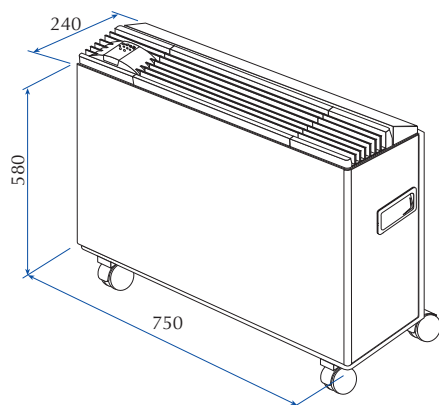

INDOOR UNIT

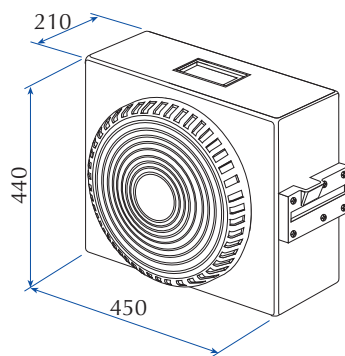

OUTDOOR UNIT

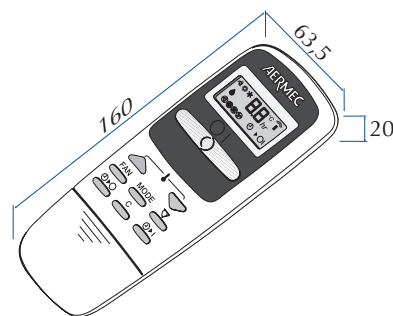

REMOTE CONTROL HANDSET

		CMX 67	CMX 67 S
Weight (kg)	Indoor unit	39	39
	Outdoor unit	12	13