



CDT 22



FUNCTION

The CDT 22 works in accordance with the condensation principle. A fan draws the humid air into the dehumidifier and through an evaporator coil. When passing through the evaporator the air is cooled down to below its dew point temperature, and its content of water vapour is condensed into water, which falls into the drip tray and then is led from the drip tray to a drain or it is collected in the water tank. The cold, dry air is then passed over the condenser coil where it is re-heated, before leaving the unit at a temperature which is approx. 5°C higher than at the inlet.

CONSTRUCTION

- The CDT 22 is built into a hot-galvanized sheet metal cabinet
- All external parts of the cabinet are enamel powder painted
- Large wheels for easy transport on any surface
- Ergonomically designed drawing handles for ease of handling and transportation
- Air intake through a filter, which is fitted in a removable filter cassette
- Automatic tank-full cut-out
- The no-spill water tank is fitted with a handle allowing easy emptying
- Drip tray with drain outlet for connection to a 1/2" water hose
- Built-in hour run meter
- Stackable
- Reciprocating compressor
- Axial fan
- If a controlled or constant relative humidity is required, the CDT 22 can be fitted with a hygrostat (optional extra)

ELECTRONIC CONTROL

The CDT 22 is fully automatic with electronic control. An easy to read display panel indicates the current status of operation.

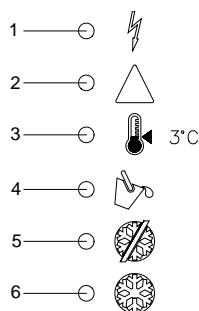

1. Power on
2. Cooling circuit failure – the dehumidifier is switched off
3. Ambient temperature below 3°C – the dehumidifier is switched off. The dehumidifier starts again automatically when the ambient temperature increases to more than 3°C
4. The dehumidifier is switched off because the water tank is full
5. Defrosting mode – the evaporator is being defrosted
6. The evaporator is icing up. The defrosting function allows icing up for 44 minutes before defrosting is activated

Active, demand-controlled defrosting is incorporated in the electronic control. A sensor on the evaporator coil ensures that the evaporator is only defrosted when required. The evaporator coil is defrosted by means of hot refrigerant bypassing the condenser and being fed through the evaporator.



TECHNICAL DATA

		CDT 22
Operating range – humidity	%RH	40 – 100
Operating range – temperature	°C	3 – 30
Air volume	m ³ /h	280
Power supply	V/Hz	1x230/50
Max. ampere consumption	A	2,9
Max. power consumption	kW	0,6
Refrigerant		R407C
Quantity of refrigerant	kg	0,300
Sound level (at 1 metre)	dB(A)	57
Weight	kg	42
Water tank capacity	litres	5,5
Colour	RAL	7024/7044
Protection class		IPX2

CAPACITY CURVES

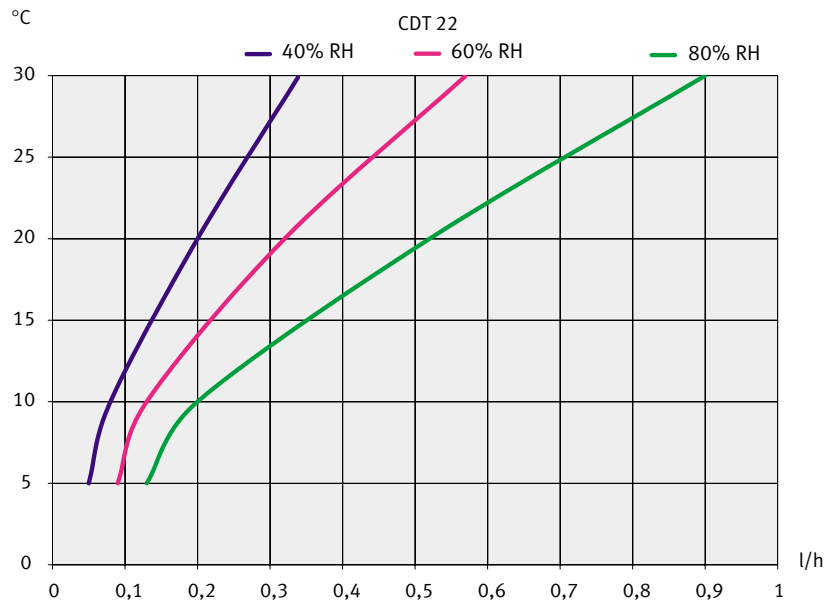

DIMENSIONS

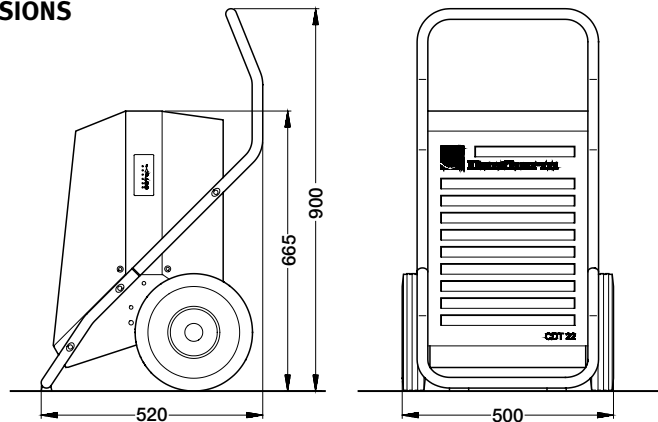

ACCESSORIES

- Hygrostat with jack-plug and 0,4 m cable
- Hygrostat with jack-plug and 3,0 m cable
- Wall suspension bracket

All dimensions are in mm



CDT 35



FUNCTION

The CDT 35 works in accordance with the condensation principle. A fan draws the humid air into the dehumidifier and through an evaporator coil. When passing through the evaporator the air is cooled down to below its dew point temperature, and its content of water vapour is condensed into water, which falls into the drip tray and then is led from the drip tray to a drain or it is collected in the water tank. The cold, dry air is then passed over the condenser coil where it is re-heated, before leaving the unit at a temperature, which is approx. 5°C higher than at the inlet.

CONSTRUCTION

- The CDT 35 is built into a hot-galvanized sheet metal cabinet
- All external parts of the cabinet are enamel powder painted
- Large wheels for easy transport on any surface
- Ergonomically designed drawing handles for ease of handling and transportation
- Air intake through a filter, which is fitted in a removable filter cassette
- Automatic tank-full cut-out
- The no-spill water tank is fitted with a handle allowing easy emptying
- Drip tray with drain outlet for connection to a 1/2" water hose
- Built-in hour run meter
- Stackable
- Rotary compressor
- Axial fan
- If a controlled or constant relative humidity is required, the CDT 35 can be fitted with a hygostat (optional extra)

ELECTRONIC CONTROL

The CDT 35 is fully automatic with electronic control. An easy to read display panel indicates the current status of operation.

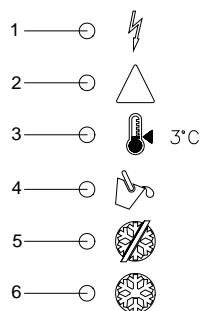

1. Power on
2. Cooling circuit failure – the dehumidifier is switched off
3. Ambient temperature below 3°C – the dehumidifier is switched off. The dehumidifier starts again automatically when the ambient temperature increases to more than 3°C
4. The dehumidifier is switched off because the water tank is full
5. Defrosting mode – the evaporator is being defrosted
6. The evaporator is icing up. The defrosting function allows icing up for 44 minutes before defrosting is activated

Active, demand-controlled defrosting is incorporated in the electronic control. A sensor on the evaporator coil ensures that the evaporator is only defrosted when required. The evaporator coil is defrosted by means of hot refrigerant bypassing the condenser and being fed through the evaporator.



TECHNICAL DATA

		CDT 35
Operating range – humidity	%RH	40 – 100
Operating range – temperature	°C	3 – 30
Air volume	m ³ /h	400
Power supply	V/Hz	1x230/50
Max. ampere consumption	A	2,7
Max. power consumption	kW	0,7
Refrigerant		R407C
Quantity of refrigerant	kg	0,475
Sound level (at 1 metre)	dB(A)	59
Weight	kg	50
Water tank capacity	litres	12,5
Colour	RAL	7024/7044
Protection class		IPX2

CAPACITY CURVES

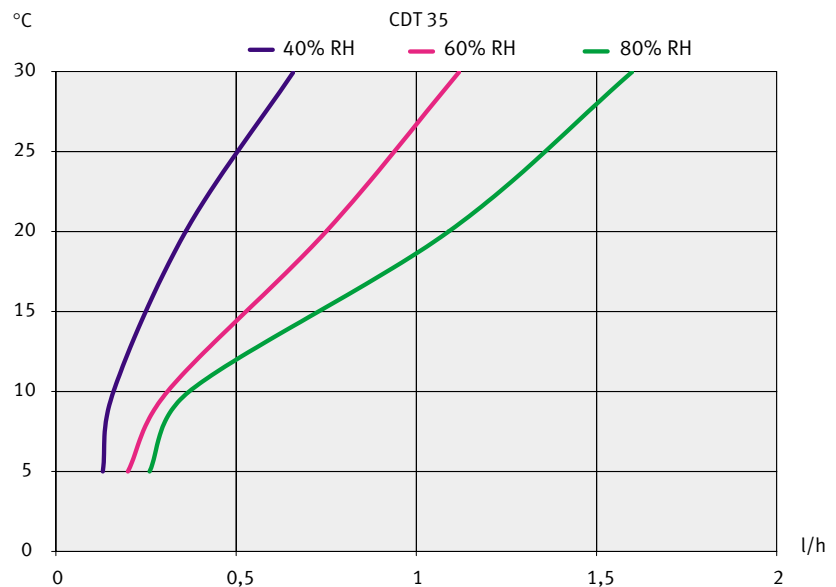

DIMENSIONS

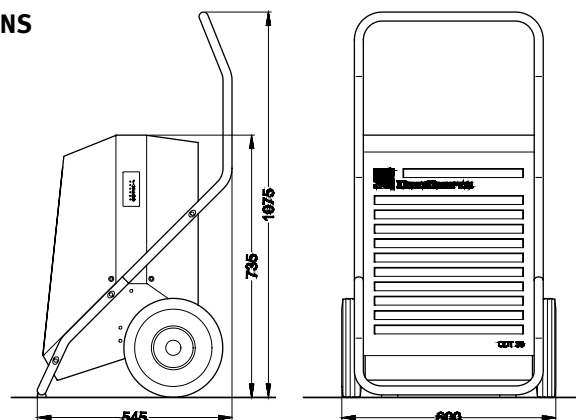

ACCESSORIES

Hygrostat with jack-plug and 0,4 m cable

Hygrostat with jack-plug and 3,0 m cable

Wall suspension bracket

All dimensions are in mm



CDT 35 S

FUNCTION

The CDT 35S works in accordance with the condensation principle. A fan draws the humid air into the dehumidifier and through an evaporator coil. When passing through the evaporator the air is cooled down to below its dew point temperature, and its content of water vapour is condensed into water, which falls into the drip tray and then is led from the drip tray to a drain or it is collected in the water tank. The cold, dry air is then passed over the condenser coil where it is re-heated, before leaving the unit at a temperature, which is approx. 5°C higher than at the inlet.

CONSTRUCTION

- The CDT 35S is built into a hot-galvanized sheet metal cabinet
- All external parts of the cabinet are enamel powder painted
- Large wheels for easy transport on any surface
- Ergonomically designed drawing handles for ease of handling and transportation
- Air intake through a filter, which is fitted in a removable filter cassette.
- On the unit front two Ø100mm flex. hoses may be connected for distribution of the hot outlet air (max. length of hoses: 5 m each) (optional extra)
- CDT 35S has a built-in 1 kW heating element for increased outlet temperature
- Automatic tank-full cut-out
- The no-spill water tank is fitted with a handle allowing easy emptying
- Drip tray with drain outlet for connection to a 1/2" water hose
- Built-in hour run meter
- Stackable
- Rotary compressor
- Axial and radial fan
- If a controlled or constant relative humidity is required the CDT 35S can be fitted with a hygrostat (optional extra)

ELECTRONIC CONTROL

The CDT 35S is fully automatic with electronic control. An easy to read display panel indicates the current status of operation.

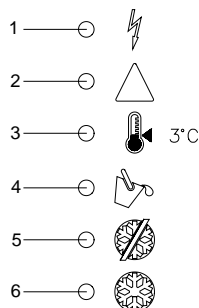

1. Power on
2. Cooling circuit failure – the dehumidifier is switched off
3. Ambient temperature below 3°C – the dehumidifier is switched off. The dehumidifier starts again automatically when the ambient temperature increases to more than 3°C
4. The dehumidifier is switched off because the water tank is full
5. Defrosting mode – the evaporator is being defrosted
6. The evaporator is icing up. The defrosting function allows icing up for 44 minutes before defrosting is activated

Active, demand-controlled defrosting is incorporated in the electronic control. A sensor on the evaporator coil ensures that the evaporator is only defrosted when required. The evaporator coil is defrosted by means of hot refrigerant bypassing the condenser and being fed through the evaporator.



TECHNICAL DATA

		CDT 35S
Operating range – humidity %	%RH	40 – 100
Operating range – temperature	°C	3 – 30
Air volume	m ³ /h	650
Power supply	V/Hz	1x230/50
Max. ampere consumption without heating element	A	3,7
Max. power consumption without heating element	kW	0,9
Max. ampere consumption with heating element	A	8,0
Max. power consumption with heating element	kW	1,9
Refrigerant		R407C
Quantity of refrigerant	kg	0,475
Sound level (at 1 metre)	dB(A)	62
Weight	kg	58
Water tank capacity	litres	12,5
Colour	RAL	7024/7044
Protection class		IPX2

CAPACITY CURVES

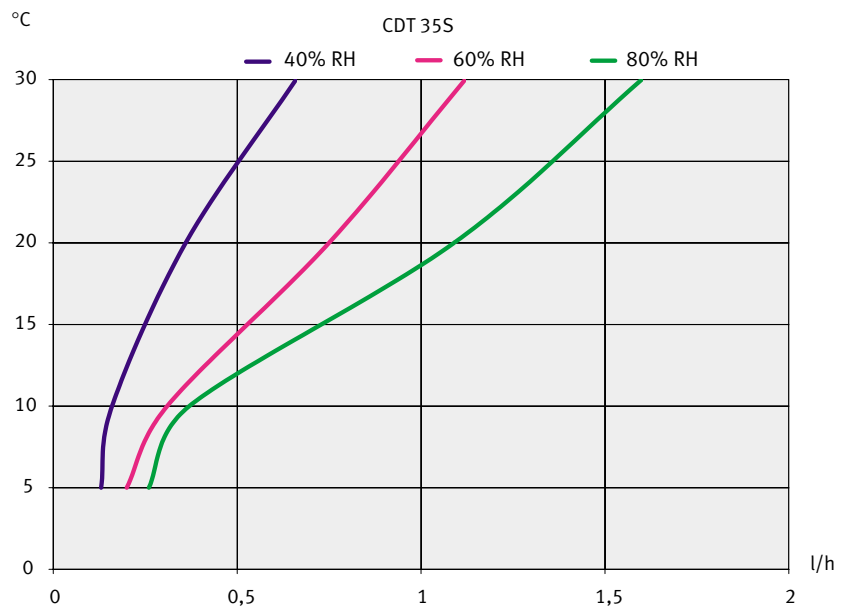

DIMENSIONS

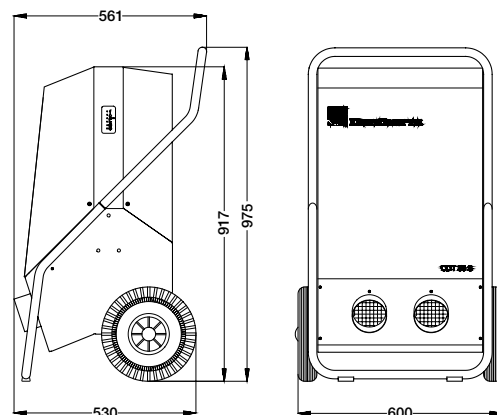

ACCESSORIES

- Hygostat with jack-plug and 0,4 m cable
- Hygostat with jack-plug and 3,0 m cable
- Flexible hoses Ø100mm
- Wall suspension bracket

All dimensions are in mm



CDT 50



FUNCTION

The CDT 50 works in accordance with the condensation principle. A fan draws the humid air into the dehumidifier and through an evaporator coil. When passing through the evaporator the air is cooled down to below its dew point temperature, and its content of water vapour is condensed into water, which falls into the drip tray and then is led from the drip tray to a drain or it is collected in the water tank. The cold, dry air is then passed over the condenser coil where it is re-heated, before leaving the unit at a temperature, which is approx. 5°C higher than at the inlet.

CONSTRUCTION

- The CDT 50 is built into a hot-galvanized sheet metal cabinet
- All external parts of the cabinet are enamel powder painted
- Large wheels for easy transport on any surface
- Ergonomically designed drawing handles for ease of handling and transportation
- Air intake through a filter, which is fitted in a removable filter cassette.
- Automatic tank-full cut-out
- The no-spill water tank is fitted with a handle allowing easy emptying
- Drip tray with drain outlet for connection to a 1/2" water hose
- Built-in hour run meter
- Stackable
- Rotary compressor
- Axial fan
- If a controlled or constant relative humidity is required, the CDT 50 can be fitted with a hygostat (optional extra)

ELECTRONIC CONTROL

The CDT 50 is fully automatic with electronic control. An easy to read display panel indicates the current status of operation.

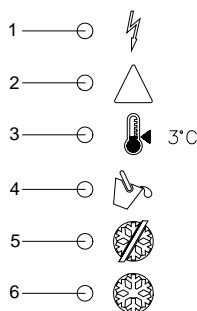

1. Power on
2. Cooling circuit failure – the dehumidifier is switched off
3. Ambient temperature below 3°C – the dehumidifier is switched off. The dehumidifier starts again automatically when the ambient temperature increases to more than 3°C
4. The dehumidifier is switched off because the water tank is full
5. Defrosting mode – the evaporator is being defrosted
6. The evaporator is icing up. The defrosting function allows icing up for 44 minutes before defrosting is activated

Active, demand-controlled defrosting is incorporated in the electronic control. A sensor on the evaporator coil ensures that the evaporator is only defrosted when required. The evaporator coil is defrosted by means of hot refrigerant bypassing the condenser and being fed through the evaporator.



TECHNICAL DATA

		CDT 50
Operating range – humidity %	%RH	40 – 100
Operating range – temperature	°C	3 – 30
Air volume	m ³ /h	800
Power supply	V/Hz	1x230/50
Max. ampere consumption	A	4,1
Max. power consumption kW	kW	0,950
Refrigerant		R407C
Quantity of refrigerant	kg	0,575
Sound level (at 1 metre)	dB(A)	61
Weight	kg	54
Water tank capacity	litres	12,5
Colour	RAL	7024/7044
Protection class		IPX2

CAPACITY CURVES

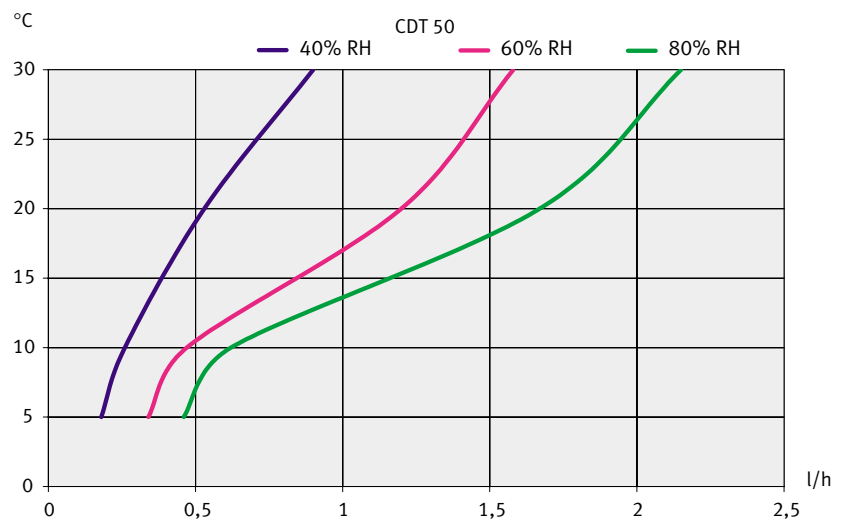

DIMENSIONS

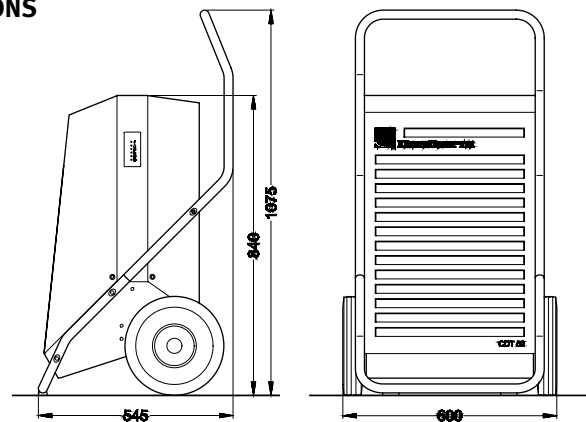

ACCESSORIES

Hygostat with jack-plug and 0,4 m cable

Hygostat with jack-plug and 3,0 m cable

Wall suspension bracket

All dimensions are in mm



CDT 85



FUNCTION

The CDT 85 works in accordance with the condensation principle. A fan draws the humid air into the dehumidifier and through an evaporator coil. When passing through the evaporator the air is cooled down to below its dew point temperature, and its content of water vapour is condensed into water, which falls into the drip tray and is led from the drip tray to a drain. The cold, dry air is then passed over the condenser coil where it is re-heated, before leaving the unit at a temperature, which is approx. 5°C higher than at the inlet.

CONSTRUCTION

- The CDT 85 is built into a hot-galvanized sheet metal cabinet
- All external parts of the cabinet are enamel powder painted
- Large wheels for easy transport on any surface
- Ergonomically designed drawing handles for ease of handling and transportation
- Air intake through a filter, which is fitted in a removable filter cassette.
- Drip tray with drain outlet for connection to a 1/2" water hose
- Built-in hour run meter
- Rotary compressor
- Axial fan
- If a controlled or constant relative humidity is required, the CDT 85 can be fitted with a hygrostat (optional extra)

ELECTRONIC CONTROL

The CDT 85 is fully automatic with electronic control. An easy to read display panel indicates the current status of operation.

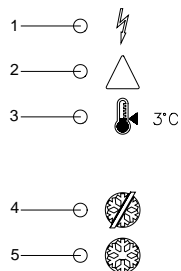

1. Power on
2. Cooling circuit failure – the dehumidifier is switched off
3. Ambient temperature below 3°C – the dehumidifier is switched off. The dehumidifier starts again automatically when the ambient temperature increases to more than 3°C
4. Defrosting mode – the evaporator is being defrosted
5. The evaporator is icing up. The defrosting function allows icing up for 44 minutes before defrosting is activated

Active, demand-controlled defrosting is incorporated in the electronic control. A sensor on the evaporator coil ensures that the evaporator is only defrosted when required. The evaporator coil is defrosted by means of hot refrigerant bypassing the condenser and being fed through the evaporator.



TECHNICAL DATA

		CDT 85
Operating range – humidity	%RH	40 – 100
Operating range – temperature	°C	3 – 30
Air volume	m ³ /h	1000
Power supply	V/Hz	1x230/50
Max. ampere consumption	A	6,9
Max. power consumption	kW	1,5
Refrigerant		R407C
Quantity of refrigerant	kg	1,600
Sound level (at 1 metre)	dB(A)	64
Weight	kg	72
Colour	RAL	7024/7044
Protection class		IPX2

CAPACITY CURVES

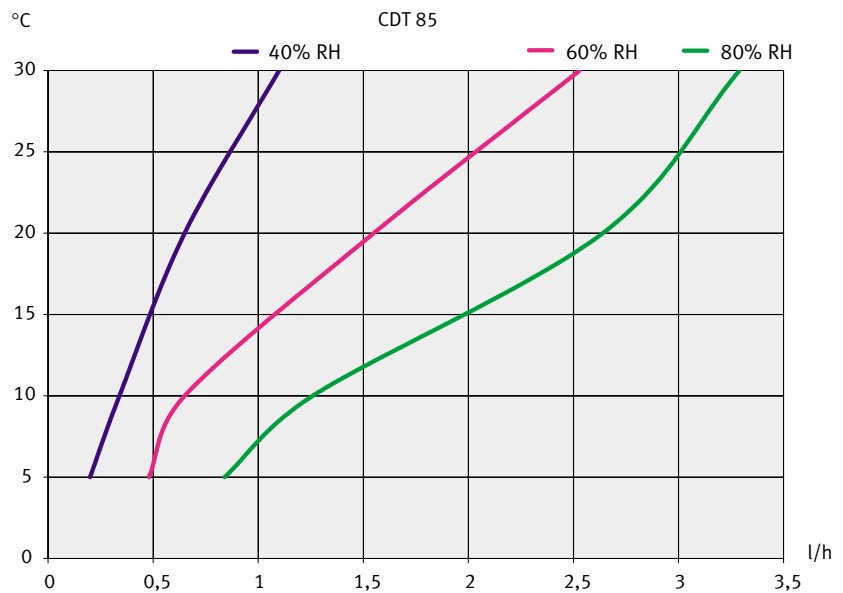

DIMENSIONS

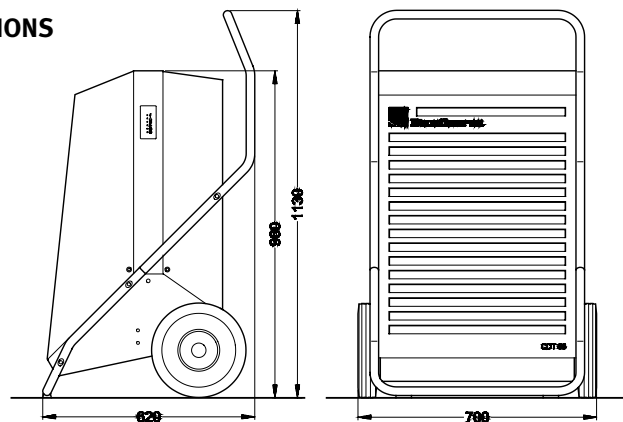

ACCESSORIES

- Hygostat with jack-plug and 0,4 m cable
- Hygostat with jack-plug and 3,0 m cable

All dimensions are in mm

**ACCESSORY**

Wall suspension bracket for
CDT 22/35/35S/50



The wall suspension bracket allows the CDT 22/35/35S/50 to be hung on a wall.

The wheels have to be removed before hanging the dehumidifier on the wall.

The wall brackets are mounted as shown on the drawing below.

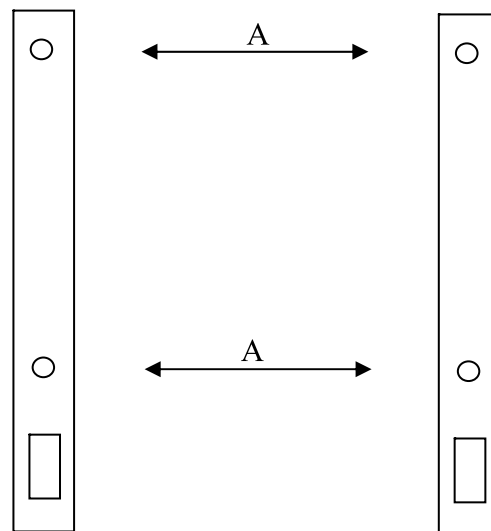

	CDT 22	CDT 35	CDT 35S	CDT 50
A	410	510	510	510

All dimensions are in mm



CDS 80

FUNCTION

The CDS 80 works in accordance with the condensation principle. A fan draws the humid air into the dehumidifier and through an evaporator coil. When passing through the evaporator the air is cooled down to below its dew point temperature, and its content of water vapour is condensed into water, which falls into the drip tray and then is led from the drip tray to a drain. The cold, dry air is then passed over the condenser coil where it is re-heated, before leaving the unit at a temperature, which is approx. 5°C higher than at the inlet.

CONSTRUCTION

- The CDS 80 is built into a hot-galvanized sheet metal cabinet
- All external parts of the cabinet are enamel powder painted
- The condensate outlet is located at the bottom right hand side of the CDS 80. The outlet stub can be connected to a Ø32mm permanent pipe installation
- The CDS 80 is operated from a control panel on front of the unit. Power is connected either at the rear or at the top of the unit
- Air intake through removable filters on three sides of the unit
- Dry air outlet through louvres at the top of the unit
- Reciprocating compressor
- Radial fan
- Ducts can be connected at the top of the unit
- A 7.2 kW heating element may be fitted for additional heating of the outlet air (optional extra).

ELECTRONIC CONTROL

The CDS 80 is fully automatic with electronic control. If a controlled and constant relative humidity is required, the CDS 80 can be fitted with a room hygrostat. If the CDS 80 is used with a heating element, the control is prepared for connection of a room thermostat.

Continuous ventilation without dehumidification can be selected on the CDS 80 control panel.

Active, demand-controlled defrosting is incorporated in the electronic control. A sensor on the evaporator coil ensures that the evaporator is only defrosted when required. During defrosting the cooling circuit is reversed by a four-way valve, which means that the evaporator will act as a condenser as long as the defrosting function is activated.

The CDS 80 is automatically switched off when the ambient temperature is outside the working range of 5-32°C. It restarts when the ambient temperature is within the working range.



TECHNICAL DATA

		CDS 80
Operating range – humidity	%RH	30 – 100
Operating range – temperature	°C	5 – 32
Air volume	m ³ /h	1600
Power supply	V/Hz	3x400/50
Max. ampere consumption without heating element	A	5,8
Max. power consumption without heating element	kW	2,5
Max. ampere consumption with heating element	A	16,2
Max. power consumption with heating element	kW	9,7
Refrigerant		R407C
Quantity of refrigerant	kg	2,250
Sound level (at 1 metre)	dB(A)	61
Weight	kg	196
Protection class	IP	X2

CAPACITY CURVES

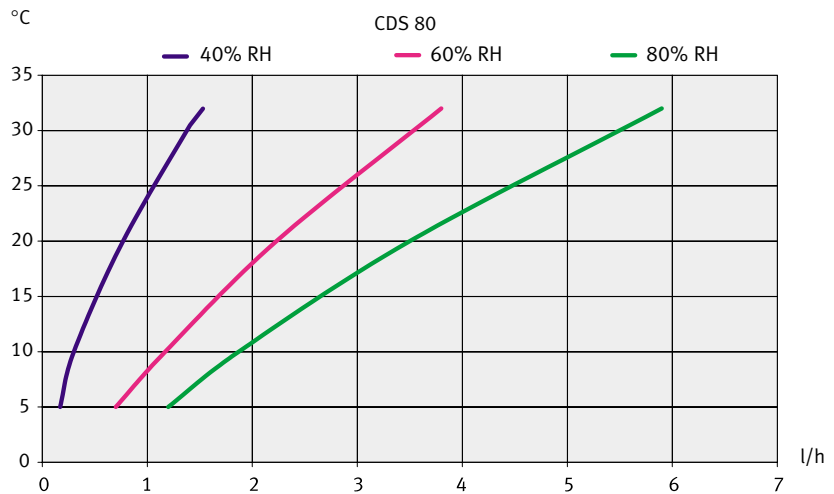

DIMENSIONS

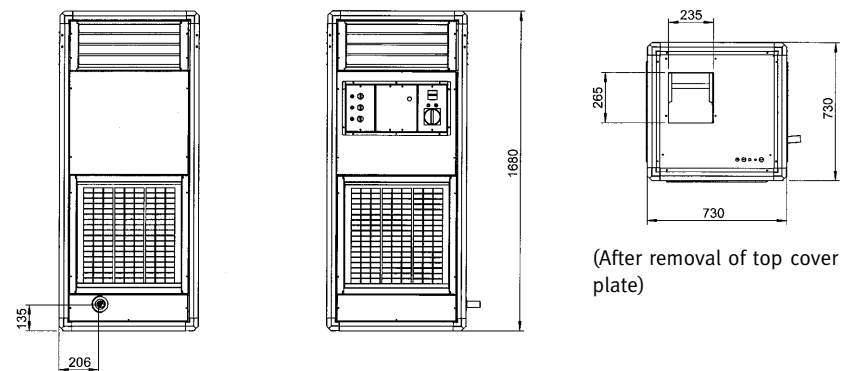

ACCESSORIES

- Room hygrostat
- Room thermostat
- 7.2 kW heating element

All dimensions are in mm



CDS 100

FUNCTION

The CDS 100 works in accordance with the condensation principle. A fan draws the humid air into the dehumidifier and through an evaporator coil. When passing through the evaporator the air is cooled down to below its dew point temperature, and its content of water vapour is condensed into water, which falls into the drip tray and then is led from the drip tray to a drain. The cold, dry air is then passed over the condenser coil where it is re-heated, before leaving the unit at a temperature, which is approx. 5°C higher than at the inlet.

CONSTRUCTION

- The CDS 100 is built into a hot-galvanized sheet metal cabinet
- All external parts of the cabinet are enamel powder painted
- The condensate outlet is located at the bottom right hand side of the CDS 100. The outlet stub can be connected to a Ø32mm permanent pipe installation
- The CDS 100 is operated from a control panel on front of the unit. Power is connected either at the rear or at the top of the unit
- Air intake through removable filters on three sides of the unit
- Dry air outlet through louvres at the top of the unit
- Reciprocating compressor
- Radial fan
- Ducts can be connected at the top of the unit
- A 7.2 kW heating element may be fitted for additional heating of the outlet air (optional extra)

ELECTRONIC CONTROL

The CDS 100 is fully automatic with electronic control. If a controlled and constant relative humidity is required, the CDS 100 can be fitted with a room hygostat. If the CDS 100 is used with a heating element, the control is prepared for connection of a room thermostat.

Continuous ventilation without dehumidification can be selected on the CDS 100 control panel.

Active, demand-controlled defrosting is incorporated in the electronic control. A sensor on the evaporator coil ensures that the evaporator is only defrosted when required. During defrosting the cooling circuit is reversed by a four-way valve, which means that the evaporator will act as a condenser as long as the defrosting function is activated.

The CDS 100 is automatically switched off when the ambient temperature is outside the working range of 5-32°C. It restarts when the ambient temperature is within the working range.



TECHNICAL DATA

		CDS 100
Operating range – humidity	%RH	30 – 100
Operating range – temperature	°C	5 – 32
Air volume	m ³ /h	2800
Power supply	V/Hz	3x400/50
Max. ampere consumption without heating element	A	9,1
Max. power consumption without heating element	kW	3,8
Max. ampere consumption with heating element	A	19,5
Max. power consumption with heating element	kW	11,0
Refrigerant		R407C
Quantity of refrigerant	kg	4,300
Sound level (at 1 metre)	dB(A)	63
Weight	kg	254
Protection class	IP	X2

CAPACITY CURVES

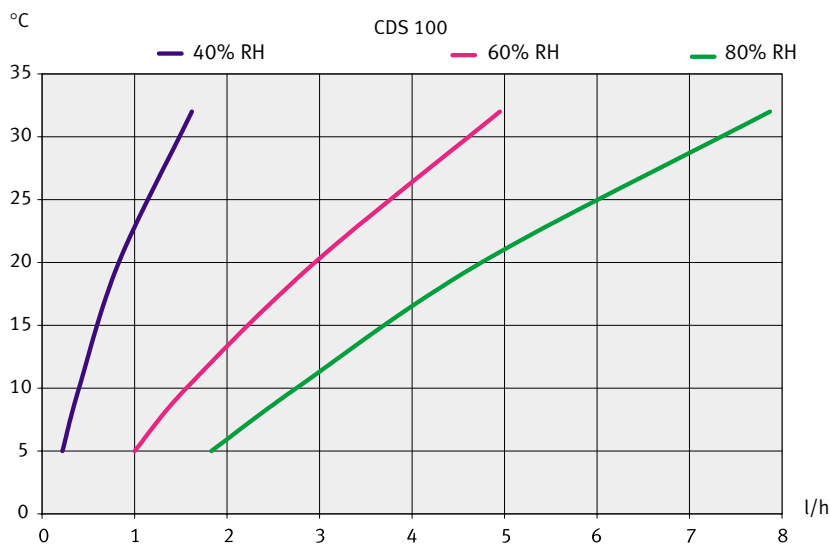

DIMENSIONS

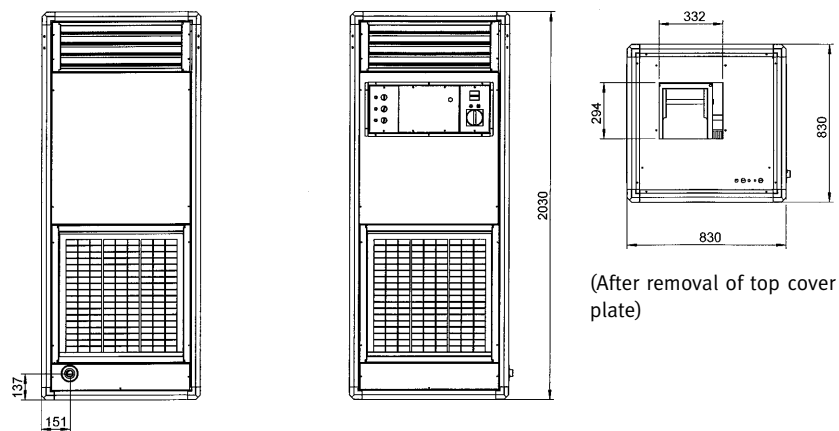

ACCESSORIES

- Room hygrostat
- Room thermostat
- 7.2 kW heating element

All dimensions are in mm



CDS 200

FUNCTION

The CDS 200 works in accordance with the condensation principle. A fan draws the humid air into the dehumidifier and through an evaporator coil. When passing through the evaporator the air is cooled down to below its dew point temperature, and its content of water vapour is condensed into water, which falls into the drip tray and then is led from the drip tray to a drain. The cold, dry air is then passed over the condenser coil where it is re-heated, before leaving the unit at a temperature, which is approx. 5°C higher than at the inlet.

CONSTRUCTION

- The CDS 200 is built into a hot-galvanized sheet metal cabinet
- All external parts of the cabinet are enamel powder painted
- The condensate outlet is located at the bottom right hand side of the CDS 200. The outlet stub can be connected to a Ø32mm permanent pipe installation
- The CDS 200 is operated from a control panel on front of the unit. Power is connected either at the rear or at the top of the unit
- Air intake through removable filters on three sides of the unit
- Dry air outlet through louvres at the top of the unit
- Reciprocating compressor
- Radial fan
- Ducts can be connected at the top of the unit
- A 7.2 kW heating element may be fitted for additional heating of the outlet air (optional extra)

ELECTRONIC CONTROL

The CDS 200 is fully automatic with electronic control. If a controlled and constant relative humidity is required, the CDS 200 can be fitted with a room hygostat. If the CDS 200 is used with a heating element, the control is prepared for connection of a room thermostat.

Continuous ventilation without dehumidification can be selected on the CDS 200 control panel.

Active, demand-controlled defrosting is incorporated in the electronic control. A sensor on the evaporator coil ensures that the evaporator is only defrosted when required. During defrosting the cooling circuit is reversed by a four-way valve, which means that the evaporator will act as a condenser as long as the defrosting function is activated.

The CDS 200 is automatically switched off when the ambient temperature is outside the working range of 5-32°C. It restarts when the ambient temperature is within the working range.



TECHNICAL DATA

		CDS 200
Operating range – humidity	%RH	30 – 100
Operating range – temperature	°C	5 – 32
Air volume	m ³ /h	3000
Power supply	V/Hz	3x400/50
Max. ampere consumption without heating element	A	13,7
Max. power consumption without heating element	kW	6,4
Max. ampere consumption with heating element	A	24,1
Max. power consumption with heating element	kW	13,6
Refrigerant		R407C
Quantity of refrigerant	kg	7,000
Sound level (at 1 metre)	dB(A)	62
Weight	kg	352
Protection class	IP	X2

CAPACITY CURVES

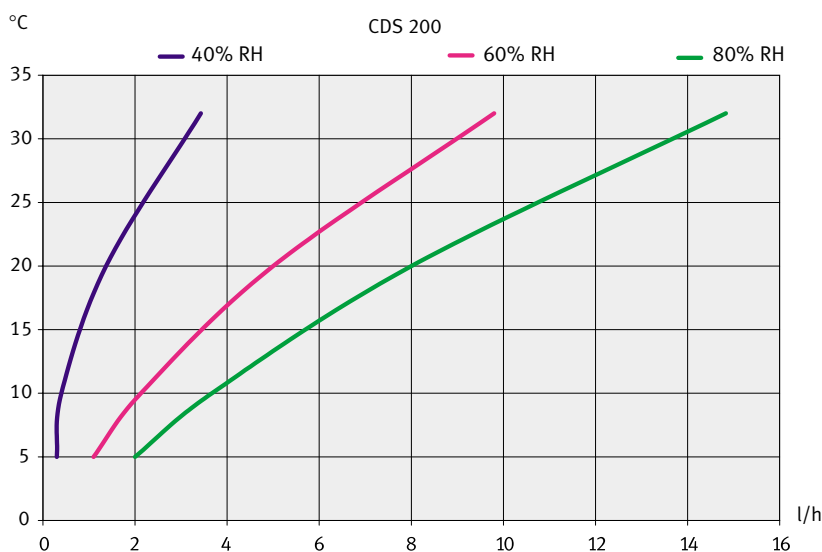

DIMENSIONS

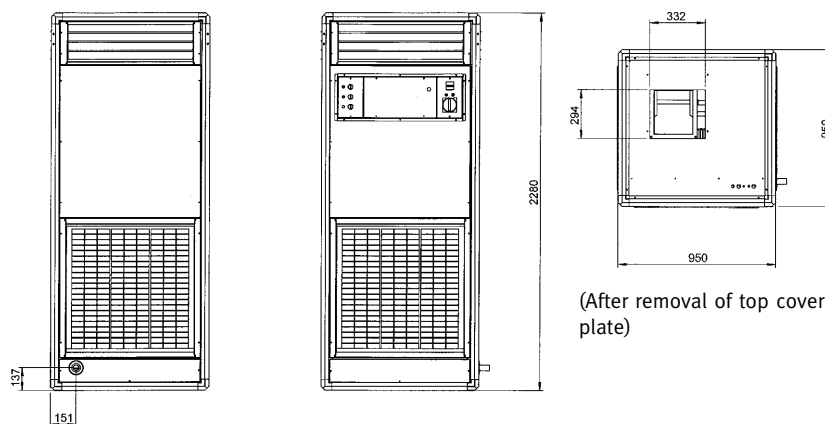

ACCESSORIES

- Room hygrostat
- Room thermostat
- 7.2 kW heating element

All dimensions are in mm