

EXHAUST EXTRACTOR

HOSE REELS **ASR, ASRM** 65, 85, 125

Mechanical and motor-driven exhaust hose reel for worksites with stationary vehicles



FUMEX provides a handy solution for work with stationary vehicles, where the hoses are out of the way when the extractor is not in use. The ASR/ASRM is available in sizes to match and handle most types of vehicles. Suitable nozzles can be found on a separate leaflet.

The ASR has a mechanical spring return. For high ceilings and cases of long and heavy hoses, there is the ASRM, a motor-driven exhaust hose reel. A push-button or a remote control is used to roll and unroll the hose. Smooth and simple at the same time as it prevents work-related injury.

The hose reels are made in powder coated steel and sheet steel.

The ASR standard brackets allow for ceiling, wall or floor mounting. Hose dimensions are 75, 100, 125 and 150 mm. The hose reel is available in three widths and is standard equipped with a crush proof EPDM hose. Standard length of the hose is 5 m and longer hoses are available at 2.5 m intervals. In addition to the length of hose that can be rolled onto the reel, a part of the hose may also be kept hanging down.

The ASR system can be equipped with an external switch, type ASR 865, for an automatic start/stop of a fan, automatic damper, etc.

The exhaust hose reel is connected to a separate fan or a central extractor system.



Wall mounted control device

Hanging control device

Radio transmitter control device

Motor drive

Hose reels and other accessories can be found in the Fumex - Belima product range.

FUMEX[®]
EXHAUST EXTRACTORS

Pure advantage

HOSE REELS ASR, ASRM

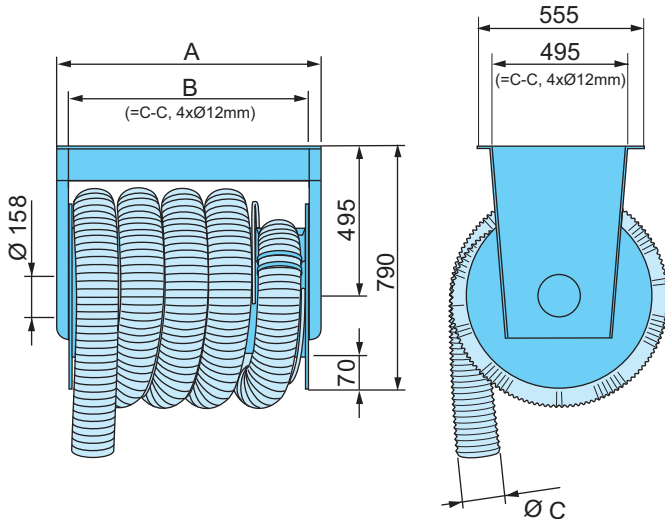

Designation		A	B	ØC	Hose length	Drop
Manual return	Motor return	(mm)	(mm)	(mm)	(m)	(m)
Dimension Ø75mm						
ASR 65-75-5	ASRM 65-75-5	835	775	75	5	0
ASR 65-75-7,5	ASRM 65-75-7,5	835	775	75	7,5	0
ASR 65-75-10	ASRM 65-75-10	835	775	75	10	0
Dimension Ø100 mm						
ASR 65-100-5	ASRM 65-100-5	835	775	100	5	0
ASR 65-100-7,5	ASRM 65-100-7,5	835	775	100	7,5	0
ASR 65-100-10	ASRM 65-100-10	835	775	100	10	1
Dimension Ø125 mm						
ASR 65-125-5	ASRM 65-125-5	835	775	125	5	0
ASR 65-125-7,5	ASRM 65-125-7,5	835	775	125	7,5	0
ASR 85-125-10	ASRM 85-125-10	1135	1075	125	10	0
ASR 85-125-12,5	ASRM 85-125-12,5	1135	1075	125	12,5	0
ASR 125-125-15	ASRM 125-125-15	1415	1355	125	15	0
Dimension Ø150 mm						
ASR 65-150-5	ASRM 65-150-5	835	775	150	5	0
ASR 85-150-7,5	ASRM 85-150-7,5	1135	1075	150	7,5	0
ASR 85-150-10	ASRM 85-150-10	1135	1075	150	10	1
ASR 125-150-12,5	ASRM 125-150-12,5	1415	1355	150	12,5	0
ASR 125-150-15	ASRM 125-150-15	1415	1355	150	15	0

ASR = Hose reel with manual spring return

ASRM = Hose reel with motor return

Notes:

1. At high ceilings, an extra hose may be kept hanging down.
2. At hose lengths over 12.5 m, motor drive is always recommended.

Accessory switches	
ASR 865	Switch for control of 24V maximum
Control devices	
ASRM-1	Wall mounted push-button up/down
ASRM-2	Hanging switch
ASRM RADIO	Radio transmitter kit (transmitter/receiver)

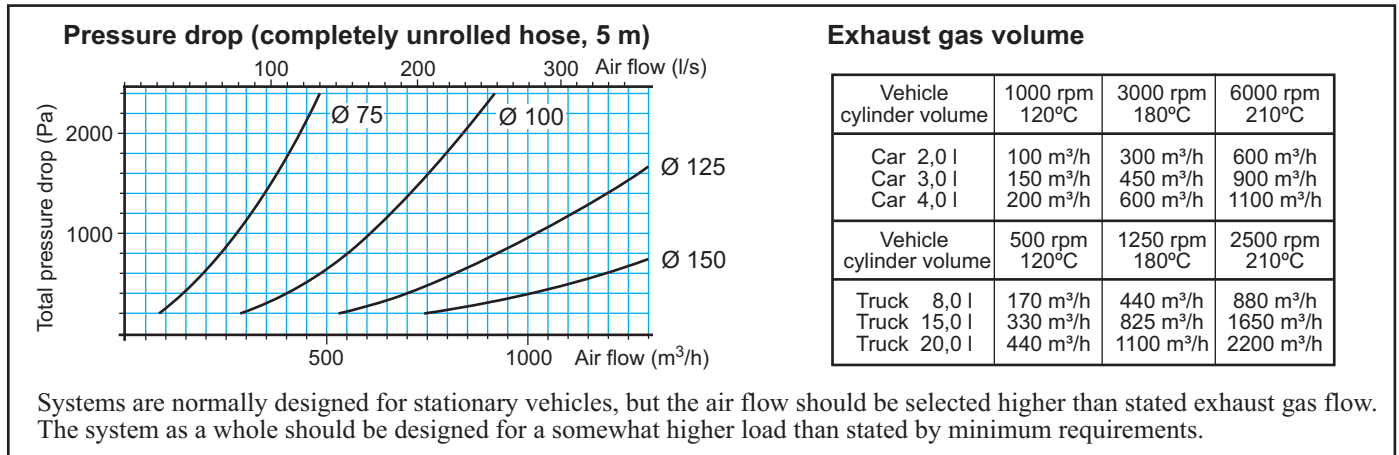

Hose

EPDM/polyester heat-resistant rubberised fabric.
Spring steel coil completely embedded in EPDM-coated reinforcement.
The hose will reshape after compression.
For other hose qualities, contact FUMEX.

Spring

Double spiral springs

Delivery design

Supplied complete with 5 m hose.
For extra hose and nozzles, see leaflet *Accessories*.

Hose

Qualities Non-inflammable, crush recoverable, suitable for exhaust fumes.
Temperature range -30°C to 170°C

Motor for the ASRM

Power 390 W
Voltage 230 V ~ 50 Hz
Push-button control, safety rate ... IP 44

Other information

Surface treatment of metal..... Powder coating
Weight without hose ASR 65: ca 47 kg
ASR 85: ca 52 kg
ASR 125: ca 57 kg

