

### R407C



Aermec adheres to the EUROVENT Certification Programme. The products concerned appear in the EUROVENT Certified Products Guide.



## • STANDARD VERSION

## • VERSION EQUIPPED WITH WATER PUMP AND STORAGE TANK

### Features

- Available in 6 different sizes
- Cooling only, heat pump and air cooled condensing versions
- All versions are supplied for use with R407C
- Cooling only version equipped with partial or total heat recovery is available
- 3 versions available:
  - Standard with water filter and flow switch
  - With low head pumping unit, 500 litre storage tank with 300 W antifreeze heater, water filter, flow switch and expansion tank
  - With high head pumping unit, 500 litre storage tank with 300W antifreeze heater, water filter, flow switch and expansion tank
- All versions except the motocondensing one can be ordered for low temperature operation for production of chilled water from 4 °C down to -6 °C. This option must be specified at the time of ordering
- High efficiency scroll compressors with low power consumption
- Modular microprocessor control system
- Functional parameters can be displayed in any of four languages
- Simplified remote control panel. All main functions of the unit, alarms included, are possible
- High efficiency plate type heat exchangers
- Evaporator electric heating element
- Electric heater for the compressor carter
- High pressure transducer
- Low pressure transducer (NRA H only)
- Axial flow fan units for extremely quiet operation
- Compact size
- Metallic protective cabinet with rustproof polyester paint

### Accessories

- **AER485:** RS-485 interface for supervision systems with MODBUS protocol.
- **DCPX:** Low temperature device for correct cooling mode operation with ambient temperatures from less than 20 °C.
- **DRE:** Electronic peak current reducer. **It must be factory-mounted.**
- **GP:** Safety grille: protects external coils from accidental impact.
- **PGS:** Daily/weekly programmer with facility to program two daily on/off cycles and set different parameters for each day of the week.
- **RIF:** Current rephaser. Parallel connection with the motor makes the reduction of input current possible. **This can only be installed when the machine is being made and must therefore be specified when the order is placed.**
- **ROMEO:** (Remote Overwatching Modem Enabling Operation) is a device that enables a remote control of a chiller from an ordinary WAP mobile phone. Furthermore it allows to send alarm or pre-alarm SMS messages up to 3 GSM mobile phones which may not be equipped with WAP. **This device includes AER485 accessory.**
- **TP 1:** Low pressure transducer: to provide working pressure readout on the microprocessor card display (one required for each circuit).
- **VT:** Anti-vibration mounts: set of four mounts for installation in locations on the underneath of the baseplate.

Compatibility of accessories																		
Mod.	500	550	600	650	700	750	500 A	550 A	600 A	650 A	700 A	750 A	500 L	550 L	600 L	650 L	700 L	750 L
	500 H	550 H	600 H	650 H	700 H	750 H							500 HL	550 HL	600 HL	650 HL	700 HL	750HL
AER485	✓	✓	✓	✓	✓	✓	✓	✓	✓	✓	✓	✓	✓	✓	✓	✓	✓	✓
DCPX 38	✓	✓	✓	✓	✓	✓	✓	✓	✓	✓	✓	✓	✓	✓	✓	✓	✓	✓
DRE	500	550	600	650	650	750	500	550	600	650	650	750	500	550	600	650	650	750
GP 2****	✓(x2)	✓(x2)	✓(x2)	✓(x2)	✓(x2)	✓(x2)	✓(x2)	✓(x2)	✓(x2)	✓(x2)	✓(x3)	✓(x3)	✓(x2)	✓(x2)	✓(x2)	✓(x3)	✓(x3)	✓(x3)
PGS	✓	✓	✓	✓	✓	✓	✓	✓	✓	✓	✓	✓	✓	✓	✓	✓	✓	✓
RIF	63	63	64	64	64	64	63	63	64	64	64	64	63	63	64	64	64	64
ROMEO	✓	✓	✓	✓	✓	✓	✓	✓	✓	✓	✓	✓	✓	✓	✓	✓	✓	✓
TP 1*	✓(x2)	✓(x2)	✓(x2)	✓(x2)	✓(x2)	✓(x2)	✓(x2)	✓(x2)	✓(x2)	✓(x2)	✓(x2)	✓(x2)	✓(x2)	✓(x2)	✓(x2)	✓(x2)	✓(x2)	✓(x2)
VT 4	✓	✓	✓	✓	✓	✓	✓	✓	✓	✓	✓	✓	✓	✓	✓	✓	✓	✓
VT 10**	✓	✓	✓	✓	✓	✓	✓	✓	✓	✓	✓	✓	✓	✓	✓	✓	✓	✓
VT 11**				✓***	✓***	✓***					✓	✓				✓	✓	✓

Mod.	500 C		550 C		600 C		650 C		700 C		750 C	
	500 LC		550 LC		650 LC		650 LC		700 LC		750 LC	
AER485		✓		✓		✓		✓		✓		✓
DCPX 38		✓(no LC)		✓(no LC)		✓(no LC)		✓(no LC)		✓(no LC)		✓(no LC)
DRE		500		550		600		650		650		750
GP 2****		✓(x2)		✓(x2)		✓(x2)		✓(x2)		✓(x3)		✓(x3)
PGS		✓		✓		✓		✓		✓		✓
RIF		63		63		64		64		64		64
ROMEO		✓		✓		✓		✓		✓		✓
TP 1		✓(x2)		✓(x2)		✓(x2)		✓(x2)		✓(x2)		✓(x2)
VT 4		✓		✓		✓		✓		✓		✓

\* = Standard on NRA H. \*\* = To be used in place of the accessory VT 4 on versions with accumulators. \*\*\* = For heat pump versions.  
 \*\*\*\* = 3 x GP 2 for NRA 650 H and 700 H N.B. = between brackets, the quantity necessary.

## Selection

By combining the various options, each model can be configured exactly to match even the most specific system requirements.

### Configuration rules:

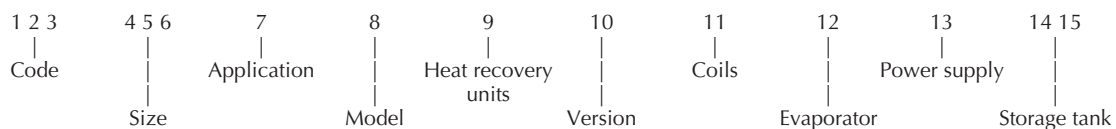

#### Code:

NRA

#### Size:

500, 550, 600, 650, 700, 750

#### Application:

- ° - Standard with produced water above +4 °C
- Y - Low temperature with produced water down to -6 °C

#### Model:

- ° - Cooling only
- H - Heat pump

#### Heat recovery units:

- ° - Without heat recovery units
- D - With desuperheaters
- T - With total recovery units

#### Version:

- ° - Standard
- A - High temperature
- L - Silenced

#### Coils:

- ° - Aluminium
- R - Copper
- S - Tinned copper
- V - Painted copper / aluminium version

#### Evaporator:

- ° - To PED standards
- C - Without evaporator

#### Power supply:

- ° - 3N~ 400V 50Hz with thermal-magnetic cut-outs
- 4 - 3~ 230V 50Hz with thermal-magnetic cut-outs
- 9 - 3~ 500V 50Hz with thermal-magnetic cut-outs

#### Storage tank:

- 00 - without accumulator
- 01 - low head storage tank and single pump
- 02 - low head storage tank and standby pump
- 03 - high head storage tank and single pump
- 04 - high head storage tank and standby pump
- 05 - storage tank with holes for supplementary heater, low head and single pump
- 06 - storage tank with holes for supplementary heater, low head and standby pump
- 07 - storage tank with holes for supplementary heater, high head and single pump
- 08 - storage tank with holes for supplementary heater, high head and standby pump

#### Warning:

- standard options are shown by symbol °;
- for cooling only versions, it is possible only the combination between options Y and A (please, contact the Headquarter for particular needs);
- Following options are not available for heat pump version: Y, T, A and C.

Commercial code example: **NRA500R402**

This code identifies an NRA unit, size 500, with copper condensing coils, evaporator to PED standard, with electrical panel for compressors with 3~ 230V 50Hz motors and low head storage tank and standby pump.

Note that as each option is precisely identified, it is not necessary to specify standard options (shown with °) in the commercial code.

## Technical data

Mod. NRA	Vers.	500	500 H	550	550 H	600	600 H	650	650 H	700	700 H	750	750H
Cooling capacity (kW)	°	94	90	103	100	120	120	138	140	153	158	180	177
	A	98	-	107	-	125	-	142	-	166	-	185	-
	L	88	87	97	96	115	115	134	130	150	150	161	154
Total input power (kW)	°	36.5	35.5	41	38	48.5	44.5	53.5	49	62	59	68	64
	A	34.2	-	37.8	-	46	-	52.5	-	58.5	-	64	-
	L	38.3	37	41.2	39.5	50	47.5	55.8	53	66	62.5	71.5	71.5
Water flow rate (l/h)	°	16170	15480	17720	17200	20640	20640	23740	24080	26320	27180	30960	30440
	A	16860	-	18400	-	21500	-	26140	-	28550	-	31820	-
	L	15140	14960	16680	16510	19780	19780	23050	22360	25800	25800	27690	26490
Pressure drops (kPa)	°	31	27.8	25.5	23.4	34.3	33.1	36.2	36.4	36.1	37.8	44	43
	A	33.5	-	27.3	-	36.7	-	36.7	-	43.6	-	47	-
	L	26.7	26.0	22.5	21.6	31.4	30.4	30.7	31.4	35.4	34.1	36	33
Working current (A)	°	65	63	72	68	87.4	82	97.5	92	108	103	120.5	115.5
	A	61.7	-	68.7	-	84.5	-	96.7	-	103.6	-	115.5	-
	L	66.5	65	71.9	70	88.4	85	99.7	96	112.3	109	124.2	123
Heating capacity (kW)	H - HL	-	102	-	112	-	134	-	155	-	177	-	202
Total input power (kW)	H - HL	-	39	-	41.5	-	49.5	-	57	-	67.5	-	79.5
Water flow rate (l/h)	H - HL	-	17540	-	19260	-	23050	-	26660	-	30440	-	34740
Pressure drops (kPa)	H - HL	-	32.8	-	27.0	-	38.0	-	41.0	-	43.6	-	55
Working current (A)	H - HL	-	66	-	73	-	85	-	100	-	112	-	137,5
Total air flow rate (m³/h)	°	37500	39500	37500	39000	37500	38500	40500	60000	54900	60000	56000	60000
	A	35500	-	35500	-	35500	-	35500	-	46350	-	56000	-
	L	17600	25000	19600	26000	23000	28000	35000	34000	34600	38000	40000	42000
♪ Sound pressure dB (A)	°	50.5	51.0	51.0	51.5	51.5	52.5	52.0	53.0	54.0	54.5	54.0	55.0
	A	50.5	-	50.5	-	51.0	-	52.0	-	52.0	-	52.0	-
	L	42.0	44.0	42.5	44.5	43.0	45.5	44.0	46.5	45.0	48.0	47.0	49.0
Compressors / circuits (n.)	All	3 / 2	3 / 2	3 / 2	3 / 2	4 / 2	4 / 2	4 / 2	4 / 2	4 / 2	4 / 2	4 / 2	4 / 2
Partialisation steps (n.)	All	3	3	3	3	4	4	4	4	4	4	4	4
Max. current (A)	All	98	98	104	104	120	120	148	148	148	148	160	160
Peak current (A)	All	215	215	222	222	239	239	253	253	260	260	314	314
Carter electric heater (W)	All	3 x 75	3 x 75	3 x 75	3 x 75	4 x 75	4 x 75	4 x 75	4 x 75	4 x 75	4 x 75	2 x 75 2 x 130	2 x 75 2 x 130
Water connections (Ø)	All	2" 1/2	2" 1/2	2" 1/2	2" 1/2	2" 1/2	2" 1/2	2" 1/2	2" 1/2	2" 1/2	2" 1/2	2" 1/2	2" 1/2
Storage tank capacity (l)	All	500	500	500	500	500	500	500	500	500	500	500	500
Effective pressure (kPa) - gr1*	°	121	128	112	116	69	69	85	80	103	99	-	-
	A	112	-	103	-	55	-	76	-	83	-	-	-
	L	134	134	123	119	82	60	93	100	117	117	-	-
Effective pressure (kPa) - gr2*	°	186	193	184	187	177	177	163	160	146	142	-	-
	A	180	-	179	-	171	-	158	-	133	-	-	-
	L	194	194	192	189	183	185	168	172	154	154	-	-

\* = gr1 (Low head pumping unit); gr2 (High head pumping unit)

Mod. NRA	Vers.	500	550	600	650	700	750
Cooling capacity (kW)	C	105	112	133	148	178	190
	LC	89	97	117	134	153	165
Total input power (kW)	C	33	36	44	50,5	56	65
	LC	38	40,5	49	55	65	71,5
Water flow rate (m³/h)	C	39.200	38.500	38.700	38.700	60.900	56.000
	LC	19.000	21.100	25.000	27.100	37.600	40.000
♪ Sound pressure dB (A)	C	50.5	50.5	51.0	52.0	52.0	52.0
	LC	42.0	42.5	43.5	44.0	45.0	47.0
Working current (A)	C	60,2	66,6	82,2	94,2	103,9	116,5
	LC	66	71,5	87,7	99,2	111,8	124,0
Compressors / circuits (n.)	All	3 / 2	3 / 2	4 / 2	4 / 2	4 / 2	4 / 2
Courant maximal (A)	C	98	104	115	145	145	160
	LC	98	104	115	145	145	160
peak current (A)	C	215	222	239	250	257	314
	LC	215	222	239	250	257	314
Refrigerant gas charge (kg)	All	11 + 13,5	11 + 15	2 x 15	2 x 16,5	2 x 22	-

Performance values refer to the following conditions:

♪ Sound pressure measured in free field conditions at distance of 10 m and direction factor = 2.

In accordance with ISO 3744 regulations  
- Power supply: 3N~ 400V 50Hz

■ Cooling:

- water outlet temperature 7 °C;  
- ambient air temperature 35 °C; Δt = 5 °C.

■ Heating:

- water outlet temperature 50 °C;  
- ambient air temperature 7 °C D.B. 6 °C W.B.; Δt = 5 °C.

■ Cooling (NRA C-LC):

- evaporation temperature 5 °C;  
- ambient air temperature 35 °C.

## Dimensions (mm)

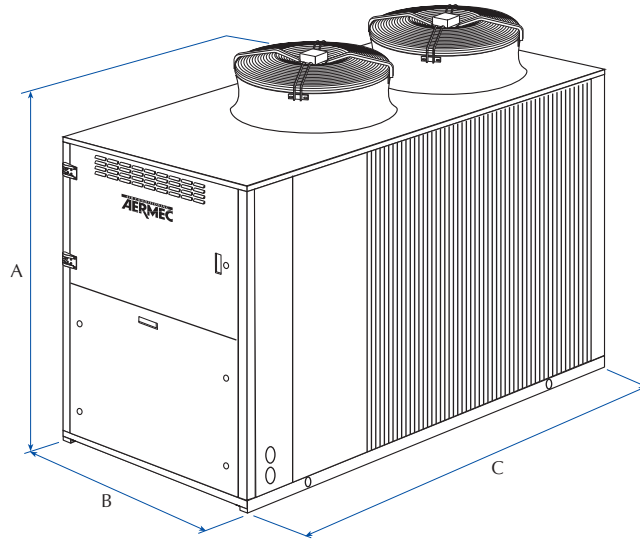

<b>Mod. NRA</b>		<b>500</b>	<b>550</b>	<b>600</b>	<b>650</b>	<b>700</b>	<b>750</b>
Standard Ver. - 00*	A	1875	1875	1875	1875	1875	1875
	B	1100	1100	1100	1100	1100	1100
	C	2950	2950	2950	2950	2950	4275
	Weight (kg)	910	935	1010	1105	1205	1530
A Version - 00*	A	1875	1875	1875	1875	1875	1875
	B	1100	1100	1100	1100	1100	1100
	C	2950	2950	2950	2950	3950	4275
	Weight (kg)	980	1005	1080	1165	1345	1530
L Version - 00*	A	1875	1875	1875	1875	1875	1875
	B	1100	1100	1100	1100	1100	1100
	C	2950	2950	2950	3950	3950	4275
	Weight (kg)	990	1040	1140	1305	1355	1560
C Version	A	1875	1875	1875	1875	1875	1875
	B	1100	1100	1100	1100	1100	1100
	C	2950	2950	2950	2950	3950	4275
	Weight (kg)	940	955	1030	1110	1285	1500
LC Version	A	1875	1875	1875	1875	1875	1875
	B	1100	1100	1100	1100	1100	1100
	C	2950	2950	2950	3950	3950	4275
	Weight (kg)	950	965	1040	1245	1295	1500
<hr/>							
<b>Mod. NRA H</b>		<b>500</b>	<b>550</b>	<b>600</b>	<b>650</b>	<b>700</b>	<b>750</b>
Standard Ver. - 00*	A	1875	1875	1875	1875	1875	1875
	B	1100	1100	1100	1100	1100	1100
	C	2950	2950	2950	3950	3950	4275
	Weight (kg)	1030	1090	1200	1370	1425	1638
L Version - 00*	A	1875	1875	1875	1875	1875	1875
	B	1100	1100	1100	1100	1100	110
	C	2950	2950	2950	3950	3950	4275
	Weight (kg)	1040	1100	1210	1380	1435	1638
<hr/>							
<b>Additional weights (kg)</b>		<b>500</b>	<b>550</b>	<b>600</b>	<b>650</b>	<b>700</b>	<b>750</b>
For* 01-05 add:		135	135	135	140	140	165
For* 02-06 add:		150	150	150	160	160	209
For* 03-07 add:		140	140	160	160	160	199
For* 04-08 add:		160	160	180	180	180	277

\* = fields 14 and 15 of the Configuration Rules

**Note:** the weights given for the versions with accumulator refer to the weight with empty storage tank.