

Air valve DAB

Plastic air valve with six-step adjustable disc and spring fastening.

PRODUCT PROPERTIES

- Diameter range 80, 100, 125, 150 and 160 mm
- Manufactured out of white polypropylen (RAL 9003) with a heat resistance up to 100 °C.
- Suitable for rooms with a higher air humidity (e.g. kitchen and bathroom).
- Easy to remove for cleaning purposes.
- Suitable for direct mounting in round, rigid ducts.
- Fast and simple to adjust by a six-step adjustable disc.
- The combination of sealing tape and spring fastening provides an optimal sealing.

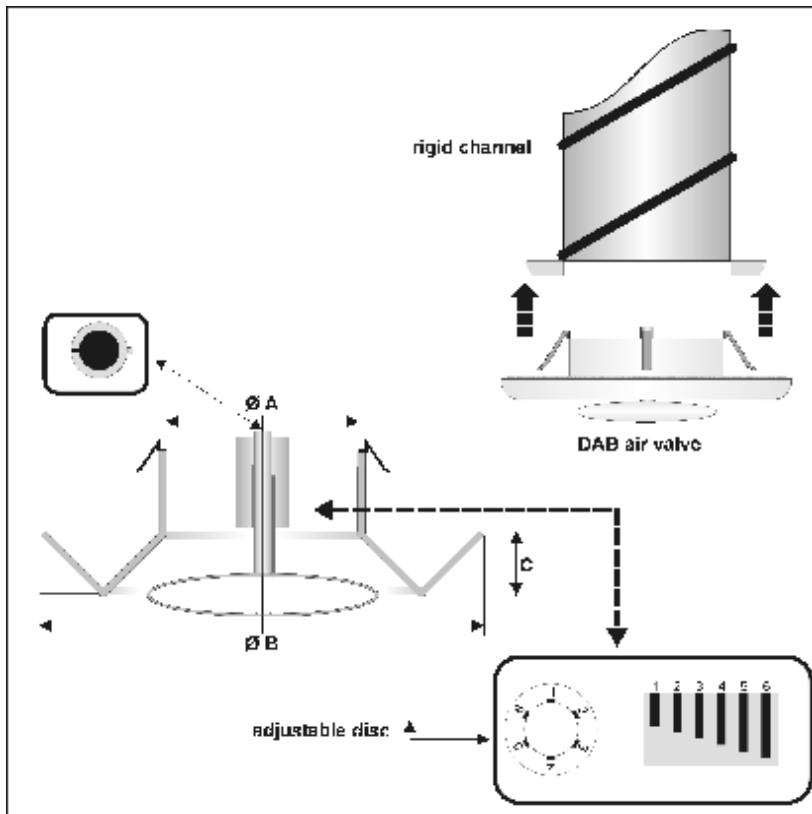

DIMENSIONS (IN MILLIMETRES)

DAB	Ø 80	Ø 100	Ø 125	Ø 150	Ø 160
A	60	80	101	118	118
B	130	150	171	186	186
C	20	20	20	20	20

The information contained in this brochure was current on the publication date. The Company reserves the right to make changes in details at any time without prior notice. In order to avoid misunderstandings, any interested party is advised to contact the Company checking for any changes in materials and/or information after this brochure was published.

Version 2003 WWW.DECINTERNATIONAL.COM

PRESSURE LOSS AND SOUND LEVEL DAB

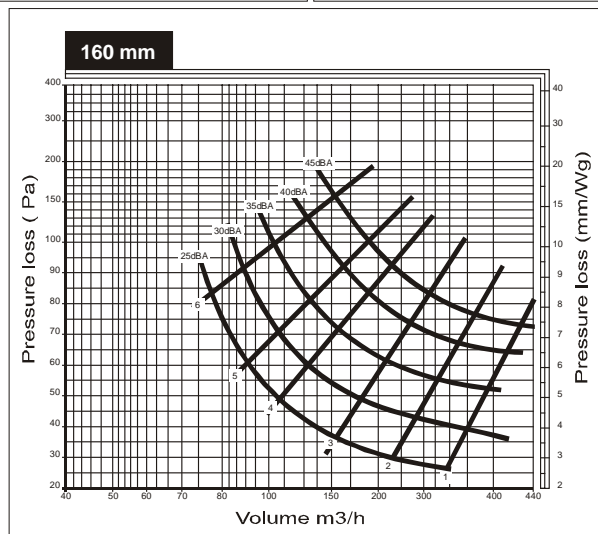
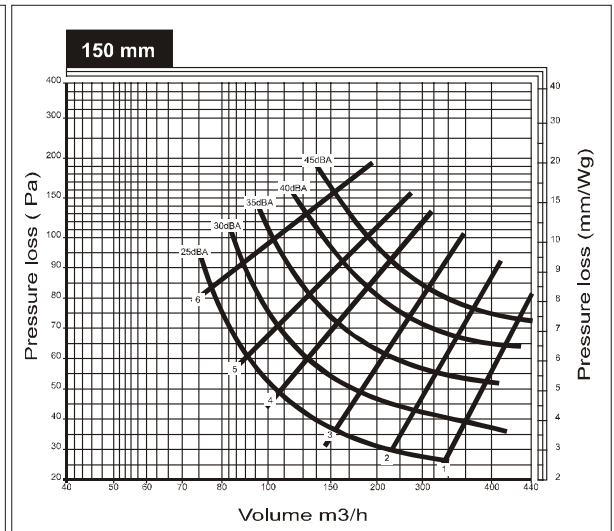
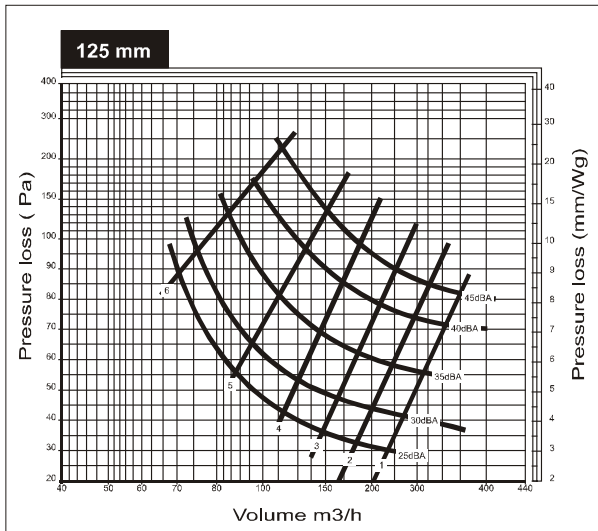
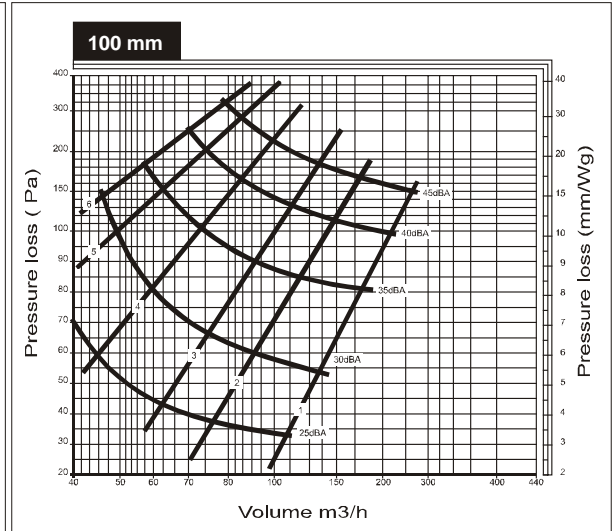
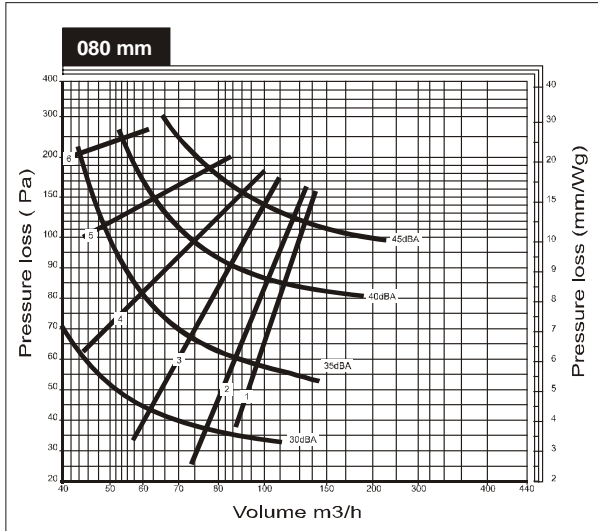

3.4

The information contained in this brochure was current on the publication date. The Company reserves the right to make changes in details at any time without prior notice. In order to avoid misunderstandings, any interested party is advised to contact the Company checking for any changes in materials and/or information after this brochure was published.

Version 2003 WWW.DECINTERNATIONAL.COM