

Omnia UL

Fan coils
Universal installations for residential applications



Aermec adheres to the EUROVENT Certification Programme. The products concerned appear in the EUROVENT Certified Products Guide.



Omnia UL

Omnia ULM

Plasmacluster
(only for Omnia UL PC)



White colour:
cover: RAL 9002
top and supports: RAL 7044

Features

- UL (Universal Line) fan coils for both horizontal and vertical installation
- 4 sizes and 8 versions:
 - UL-S: version without switch
 - UL: version with switch
 - UL-C: version with electronic thermostat
 - UL-P: ceiling mounting version without cabinet
 - UL-MS: single louver version without switch
 - UL-M: single louver version with switch
 - UL-MC: single louver version with electronic thermostat
- **UL PC:** version with electronic thermostat and Plasmacluster filter (factory-mounted only)
- EUROVENT certified
- 3-speed centrifugal fan
- Very quiet operation
- Aesthetically styled with soft flowing lines
- Adjustable air delivery louver
- Automatic power-off function with closure of the air delivery louver
- Slim dimensions
- Electronic temperature control, automatic fan speed change, automatic season changeover and automatic on - off (with electronic thermostat)
- Water connections reversibility during installation
- Low pressure drop across heat exchanger
- Motors with permanently connected condensers
- Easy installation and maintenance
- Air filter easy to remove and to clean
- Full compliance with safety regulations

Accessories

- **AMP** : Kit for wall/ceiling mounting. Standard on P, S and MS versions.
- **BC** : Auxiliary condensate drip tray. BC 10 for vertical installation BC 20 for horizontal installation
- **DSC5** : Condensate drainage device for use when natural run-off is not possible.
- **GU** : Aspiration grille, covers the front space between the stands, does not interfere with the air filter. **Use with ZU stands compulsory.**
- **PCU** : Rear cover panel.
- **SIT 3-5** : Thermostat interface cards. They allow to set up a fancoils network (max. 10) commanded by a centralised panel (switch or thermostat).
 - SIT3 : commands the three speeds of the fan and must be installed on each fancoil of the network; it receives the commands from the switch or from the SIT5 card.
 - SIT5 : commands the 3 fan speeds and up to two valves (four-pipe systems); it sends the thermostat commands to the fancoils network.
- **SW** : Water probe which enables automatic season change-over thanks to the specific electronic thermostats.
- **VCH** : Kit comprising motorized 3-way valve, unions and copper pipes.
- **ZU** : Feet for floor-standing solutions.
- **Control panels** : The control panels are described in a separate document.

Omnia UL	Compatibility of accessories				Versions
	11	16	26	36	
AMP 10	✓	✓	✓	✓	All except P, S, MS
BC 10	✓	✓	✓	✓	All
BC 20	✓	✓	✓	✓	All
DSC5	✓	✓	✓	✓	All
FMT10	✓	✓	✓	✓	S, MS, P
FMT20	✓	✓	✓	✓	S, MS, P
GU	10	15	25	35	All except P
PCU	10	15	25	35	All except P
PX2	✓	✓	✓	✓	S, MS, P
PXB	✓	✓	✓	✓	S, MS, P
PXAE	✓	✓	✓	✓	S, MS, P
PXLM	✓	✓	✓	✓	S, MS
SIT 3	✓	✓	✓	✓	S, P
SIT 5	✓	✓	✓	✓	S, P
SW3	✓	✓	✓	✓	All
VCH	✓	✓	✓	✓	All
WMT05	✓	✓	✓	✓	S, MS, P
WMT10	✓	✓	✓	✓	S, MS, P
ZU	✓	✓	✓	✓	All except P

Main features

- **Fan cleaning:** Omnia fan coils allow fan blades to be easily cleaned. It is now possible to remove the fan volute (it contains the fan blades) and clean it periodically.
- **Condensate drip tray cleaning:** Thanks to a new drip tray fitting, it is now easier to clean it with Omnia fan coils. This important solution avoids, in the long run, bacteria, germs and mould to grow up, in the drip tray because of the air humidity.
- **Precharged electrostatic filter:** Omnia fan coils have, as standard, precharged electrostatic filters. These filters, thanks to their special execution, attracts and retains all suspended dust particles, thus guaranteeing pure breathable air to the whole family.
- **PLASMACLUSTER ionising filter:** Plasmacluster is capable of reducing the level of pollutants, by decomposing the molecules that form them. Using a series of electric shocks, "Plasmacluster" causes the water molecules present in the air to separate into positive and negative ions. These ions neutralise the gas pollutant molecules, forming products that are normally present in clean air. The result is in the air: you can finally breathe clean, odour-free ionised air.
- **Silent operation:** Thanks to the use of special centrifugal fans, Omnia fan coils operation is extremely silent and offers the maximum acoustic comfort.

Technical data

Mod. Omnia		UL 11	UL 16	UL 26	UL 36
Heating capacity	W (max.)	2010	2910	4620	5940
	W (med.)	1460	2120	3830	4870
	W (min.)	1060	1540	2890	3530
Heating capacity (water inlet 50°C)*	W (E)	1150	1700	2750	3540
Water flow rate	l/h	173	250	397	511
Water pressure drop	kPa	1.6	3.7	10.5	7.4
Total cooling capacity	W (max.) (E)	840	1200	2030	2830
	W (med.)	650	950	1780	2310
	W (min.)	490	690	1420	1730
Sensible cooling capacity	W (max.) (E)	700	990	1640	2040
	W (med.)	530	750	1370	1790
	W (min.)	390	520	1050	1280
Water flow rate	l/h	144	206	349	487
Water pressure drop	kPa (E)	1.9	4.8	11.0	9.5
Air flow rate	m ³ /h (max.)	180	240	350	460
	m ³ /h (med.)	120	160	270	350
	m ³ /h (min.)	80	110	190	240
Fans	n.	1	1	2	2
Sound pressure	dB (A) (max.)	37.5	39.5	39.5	39.5
	dB (A) (med.)	28.5	34.5	34.5	32.5
	dB (A) (min.)	22.5	25.5	26.5	25.5
Sound power	dB (A) (max.) (E)	46	48	48	48
	dB (A) (med.) (E)	37	43	43	41
	dB (A) (min.) (E)	31	34	35	34
Water contents	l	0.4	0.5	0.8	1.1
Max. motor power	W (E)	18	32	35	42
Max. input current	A	0.09	0.15	0.18	0.22
Coil connections	ø	1/2"	1/2"	1/2"	1/2"

Power supply = 1 ~ 230V 50Hz.

(E) = EUROVENT certified performance

Performance values refer to the following conditions:

♪ Sound pressure measured in an 85 m³ semi-reverberant test chamber with reverberation time Tr = 0.5s.

■ Cooling:

- room air temperature 27 °C D.B., 19 °C W.B.;
- water inlet temperature 7 °C; max. speed;
- Δt water 5 °C.
- for medium and low speed, water flow rate remains same as at maximum speed.

■ Heating:

- room air temperature 20 °C;
- water inlet temperature 70 °C; maximum speed;
- Δt water 10 °C;
- for medium and low speed, water flow rate remains same as at maximum speed.

■ Heating*:

- room air temperature 20 °C;
- water inlet temperature 50 °C; maximum speed;
- water flow same as in cooling operation.

Dimensions (mm)

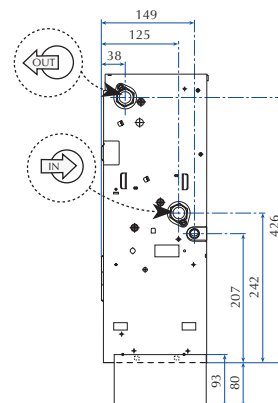
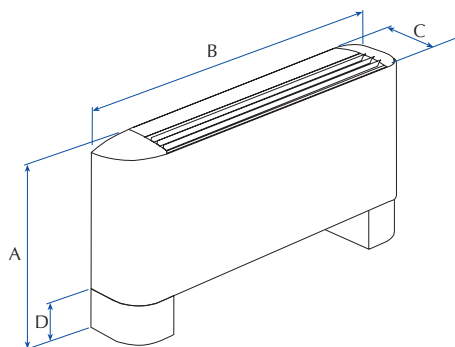

Mod Omnia		UL 11	UL 16	UL 26	UL 36
Height	A	606	606	606	606
	D	93	93	93	93
Width	B	640	750	980	1200
Depth	C	173	173	173	173
Weight	kg	12.5	13.5	16.5	19.5

The technical data in this document are not binding. Aermec S.p.A. reserves the right to make whatever modifications it deems necessary to improve the product at any time.

Aermec S.p.A.
Via Roma, 44 - 37040 Bevilacqua (VR) - Italy
Tel. +39 04 42 63 31 11 - Telefax +39 044 29 35 66
www.aermec.com