

T (standard)

Air handling unit with capacities from 15.6 to 137.8 kW



The T series constitutes an alternative to the air handling units in the range with flow rates from 3000 to 20000 m³/h in cases where requirements are limited to the filtration, cooling and/or heating for civil and industrial buildings.

The units from "T" series are manufactured for vertical installation with delivery outlet at the top, front suction and left hand connections.

Both "standard" models and those to be "configured" can be rotated on site to get different configurations (refer to manuals for models to be configured).

Features

- Frame in aluminium profiles with black nylon corner pieces and pre-plastified steel panelling
- Sandwich panels with injected polyurethane core (density 40 kg/m³), total thickness is 25 mm
- Delivery plenum with internal sound insulating lining
- Adjustable speed double suction radial fans
- Vee belt and pulley transmission; adjustable diameter driving pulley
- UNELMEC normalized motors (protection factor IP 55 and insulation class F)
- Modular structure offering the maximum versatility of installation
- Effective static pressure sufficient for connection to extensive duct networks
- Heat exchangers with 4 or 6 rows for heating and/or cooling
- Synthetic G3 class pleated filters
- Elastomer dampers under the motor cradle and on upper side of fan unit

Accessories

- **GC:** Cooling section intake grille. In anodized aluminium with single row of fixed slats.
- **M:** Delivery plenum. Made using same panelling as basic unit but equipped with an internal layer of sound insulating material. To be adopted in non-ducted installations for the delivery of processed air into the building through a louver with two rows of angle-adjustable slats. Outlet louver in anodized aluminium.
- **P:** Feet kit. Feet in galvanized steel; height of unit increases by 50 mm.

Designation codes for T series units

Position	Code	Description	
1 st	T	T series	
	1	nominal flow rate 3000 m ³ /h	
	2	nominal flow rate 4000 m ³ /h	
	3	nominal flow rate 5600 m ³ /h	
	2 nd	4	nominal flow rate 7600 m ³ /h
		5	nominal flow rate 10800 m ³ /h
		6	nominal flow rate 14000 m ³ /h
7		nominal flow rate 20400 m ³ /h	
3 rd	4	air conditioning section with 4-row coil	
	6	air conditioning section with 6-row coil	

Technical data

4-row coil		T14	T24	T34	T44	T54	T64	T74
Cooling capacity	kW	15.6	20.6	30.2	39.8	56.6	68.1	98
Heating capacity	kW	32	42.3	60.1	80.6	114	154.2	224
Max. pressure	Pa	138	174	253	235	246	290	271
Nominal air flow rate	m ³ /h	3000	4000	5600	7600	10800	14000	20400
Coil surface area	m ²	0.332	0.432	0.615	0.815	1.141	1.485	2.16
Motor power	kW	0.55	0.75	1.1	1.5	2.2	3	4
6-row coil		T16	T26	T36	T46	T56	T66	T76
Cooling capacity	kW	20.1	25.8	38.1	53	76.1	95.3	137.8
Heating capacity	kW	39	51.4	73	99.3	141	188.9	274.7
Max. pressure	Pa	117	151	228	210	220	268	249
Nominal air flow rate	m ³ /h	3000	4000	5600	7600	10800	14000	20400
Coil surface area	m ²	0.332	0.432	0.615	0.815	1.141	1.485	2.16
Motor power	kW	0.55	0.75	1.1	1.5	2.2	3	4

Power supply = 3~ 230V 50Hz; 3~ 400V 50Hz.

Performance values refer to the following conditions:

■ Cooling:

- room air temperature 27 °C D.B., 19 °C W.B.;
- water temperature 7 - 12 °C.

■ Riscaldamento:

- room air temperature 20 °C;
- water temperature 70 - 60 °C.

- pressure measured with dry coil.
- nominal air flow rate.

Selection

Modularity

The T (standard) series is composed of the following sections for each size:

- Ventilating section.
- Housing section for cooling coil, condensate drip tray and filter.

For different configurations refer to manuals for models to be configured.

Dimensions (mm)

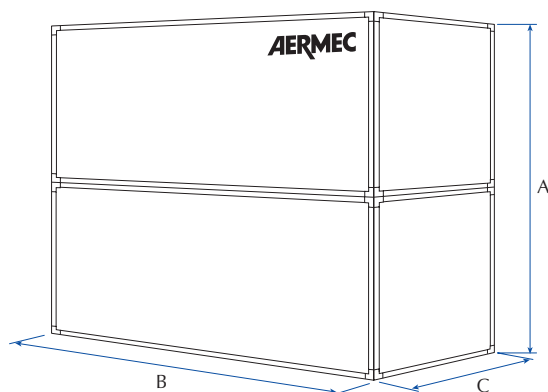

		T14/T16	T24/T26	T34/T36	T44/T46	T54/T56	T64/T66	T74/T76
Height	A	1300	1300	1480	1480	1740	1740	2260
Width	B	1100	1350	1500	1900	1900	2560	2560
Depth	C	650	650	740	740	870	870	1130