

CIRCULAR SWIRL DIFFUSER WR200

Installation dimensions

WR210

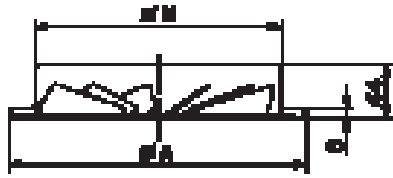

WR230

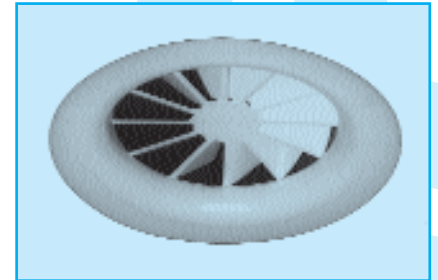
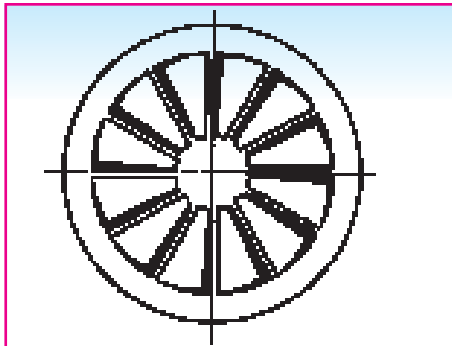
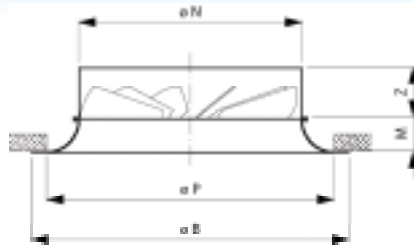

Application

The swirl diffuser type WR200 is used for the supply of cooled and heated air in facilities such as offices, shopping centres, schools, ...
Diffuser for ceiling or exposed duct mounting. The diffuser is equipped with fixed vanes in a round front-plate. A high induction is obtained by the exceptional swirl discharge, which makes them very suitable for VAV application from 100% down to 25 %. A downwards inclined swirl is obtained in the flush version WR200, when fitted with the diffusion collar WR220 a horizontal swirl is obtained.

Size	ØN	ØA	ØB	M	ØP	Z
125	123	178	200	30	170	25
160	158	198	250	30	210	35
200	198	248	300	35	250	40
250	248	298	350	35	300	45
315	313	363	450	40	390	50
400	398	600	570	70	520	50
500	498	700	700	70	620	50

Ø P = minimal ceiling opening. All dimensions in mm.

Fast selection diagram

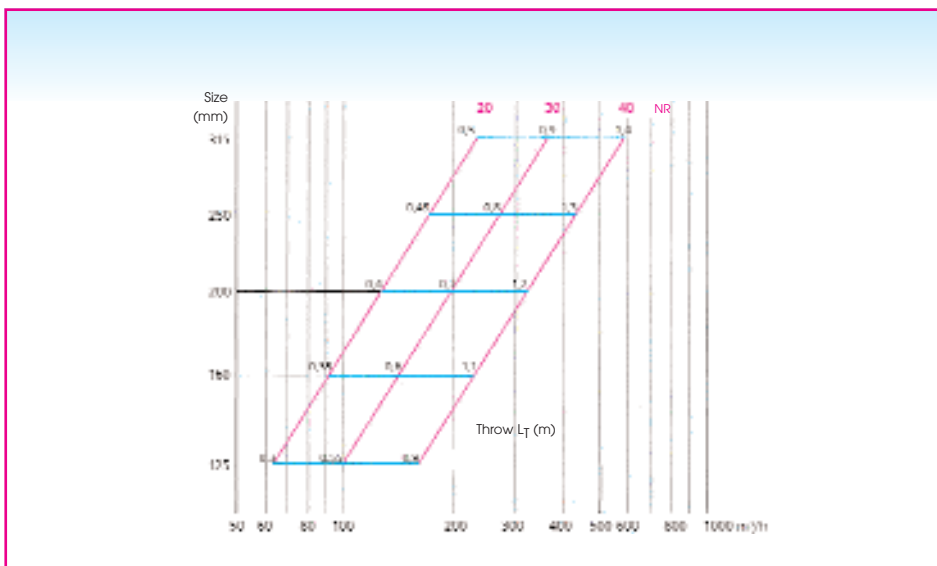

Throw factor is based on a v_R of 0,17 m/s in the occupied zone.
See p. 3 070 following pages for a detailed selection.

Technical information

Characteristics :

- available in 7 dimensions
- 2,4 < installation height < 4 m
- diffuser with central screw fixing that can be dismantled from plenum or transition piece.
- diffuser without central screw fixed to plenum or transition piece.

Construction:

- diffuser ; steel, painted in white (RAL 9010)
- insulated or non insulated plenum ; galvanised sheet steel
- provided with mounting eyes (\varnothing 7mm), mounting straps available on demand

Specifications description

Example:

Circular steel swirl diffuser with fixed vanes in a round frontplate and diffusion collar. Complete with side entry plenum and damper.

The diffuser is painted white (RAL 9010)

Type: **WR231S**
size ... mm

Accessories

- **GR003** : mounting support for central screw fixing (only for WR210 and WR230)

Possible deliveries

- **WR200**: Flush swirl diffuser
- **WR200S**: Flush swirl diffuser and plenum with side entry
- **WR200T**: Flush swirl diffuser with transition piece, top entry
- **WR210**: Flush swirl diffuser with central screw fixing
- **WR210T**: Flush swirl diffuser with central screw fixing and transition piece, top entry
- **WR210S**: Flush swirl diffuser with central screw fixing and plenum with side entry
- **WR211S**: Flush swirl diffuser with central screw fixing, plenum with side entry and damper
- **WR220**: Swirl diffuser with diffusion collar
- **WR220S**: Swirl diffuser with diffusion collar and plenum with side entry
- **WR220T**: Swirl diffuser with diffusion collar and transition piece, top entry
- **WR230**: Swirl diffuser with diffusion collar and central screw fixing
- **WR230T**: Swirl diffuser with diffusion collar, with central screw fixing and transition piece, top entry
- **WR230S**: Swirl diffuser with diffusion collar, central screw fixing and plenum with side entry
- **WR231S**: Swirl diffuser with diffusion collar, central screw fixing and damper in inlet spigot

Installation dimensions

WR210T

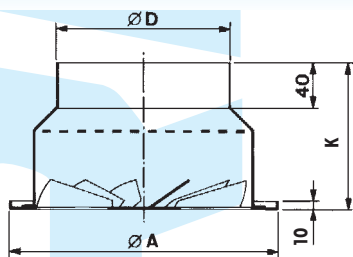

Size	C	∅D	E	F	G	H	∅J	□W	K	Q
125	129	98	154	160	230	205	127	275	126	155
160	141	123	166	185	255	230	162	325	131	160
200	159	158	184	220	290	265	202	375	131	160
250	184	198	214	270	340	315	252	475	136	165
315	204	248	239	310	390	355	317	500	144	180
400	236	313	296	375	480	420	402	600	177	240
500	278	398	338	460	565	505	502	800	-	-

WR230T

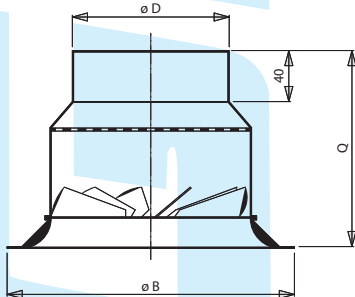

WR210S

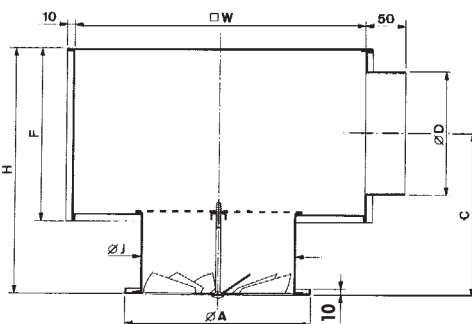

WR231S

