

LOCAL EXTRACTOR



Local extractor for explosive environments. Safe equipment when handling explosive gases and dust



R EX



R EXH



RZ EX

R EX R EXH

1500, 2000, 3000, 4000

Local extractor for workplaces which require safe handling of explosive gases and dust.

FUMEX local extractors R EX, R EXH with lengths of 1.5, 2, 3 and 4 m have a stable earthed structure, arm in steel with conductive powder coating or alternatively stainless steel and an anti-static hose.

FUMEX R EX, R EXH and RZ EX fulfil the requirements in the ATEX directive 94/9/EC category 2 for gases and dust.

RZ EX

4500, 6500

Local extractor when longer arms are required.

FUMEX®

LOCAL EXTRACTOR

Pure advantage

ATEX compliant - Local extractor from FUMEX

The standard for quality and safety for explosion protected equipment is called ATEX.

FUMEX local extractors are a safe choice within the pharmaceutical and food industries, as well as in workshop and laboratory environments.



Local extractor R EX

Wall bracket and arm in powder coated steel with conductive metallic grey paint

Stainless steel gas spring that balances the arm's dead weight.

Hose, ATEX-marked R$10^3\Omega$. Anti-static hose in Polyester-Polyurethane.

Manual damper with conductive knob.

Round handle for easy manoeuvring.



Local extractor RZ EX

An option with a longer reach, up to 6.5 m. All parts effectively earthed. Arm structure complete with wall bracket in steel, finished in conductive powder coating. Same hose from suction nozzle to duct connection provides low pressure drop, low level of dust deposits and easy cleaning.

Accessories

Conical hood in powder coated aluminium with conductive metallic grey paint.

Safe earthing

All components are safely earthed.

Alternative brackets for R EX and RZ EX



TIX EX

Adapted for ceiling mounting of R EX, R EXH-arms. Powder coated steel, with conductive metallic grey paint. Standard lengths 500, 1000 and 1500 mm.



TIX 180 EX

Adapted for ceiling mounting of R EX, R EXH-arms with an additional link facilitates 180° flexibility left and right. Powder coated steel, with conductive metallic grey paint. Standard lengths 500, 1000 and 1500 mm.

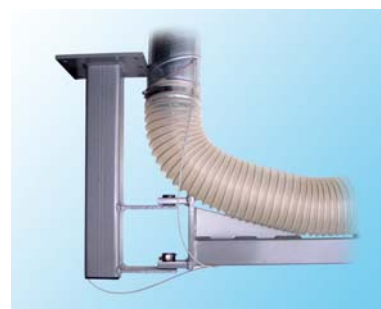

TIZ EX

Adapted for ceiling mounting of RZ EX -EXH-arms up to 6.5 m. Powder coated steel with conductive metallic grey paint. Standard lengths 500, 1000 and 1500 mm..



Local extractor R EXH

Wall bracket and arm in stainless steel.

Stainless steel components throughout for aggressive environments.

All joints and screws in stainless steel.

Stainless surface construction for easy cleaning.

Conical hood in stainless steel.

FACTS ABOUT ATEX

Why ATEX?

The need to reduce the number of explosions and explosive fires at work has led to the European Parliament adopting the so-called ATEX-directive 94/9/EC.

What is meant by a potentially explosive environment?

An environment that because of a mixture of atmospheric air and flammable substances in the form of gases, vapours, fogs or powders has the potential to be an explosive one if an ignition source is present. Examples of environments such as this are petrochemical factories, and the wood processing-, food- and pharmaceutical industries.

Zone classification

Potentially explosive areas or premises are classed in zones according to how often an explosive atmosphere occurs and how long it lasts. The individual in charge of the operation is responsible for the risk area being classified. Classification must be carried out by persons who are knowledgeable about the properties of the flammable goods, the process as well as the equipment. Classification can take place in consultation with safety- and electrical engineers, and also process technicians.

Zone 0 and zone 20

Areas where an explosive atmosphere is present continuously, for long periods or frequently.

Zone 1 and zone 21

Areas where an explosive atmosphere is likely to occur in normal operation.

Zone 2 and zone 22

Areas where an explosive atmosphere is not likely to occur in normal operation, but, if it does occur, will only be for a short duration.

Marking of ATEX products.

Local extractor from FUMEX is marked according to the plate below.

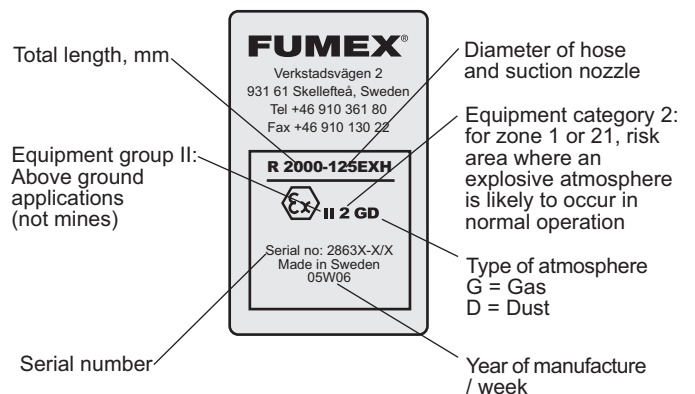

Industries and operations that can have potential explosion risk:

- Chemical and Petrochemical industries
- Gas distribution
- Paint industry
- Laboratories
- Food industry
- Pharmaceuticals industry

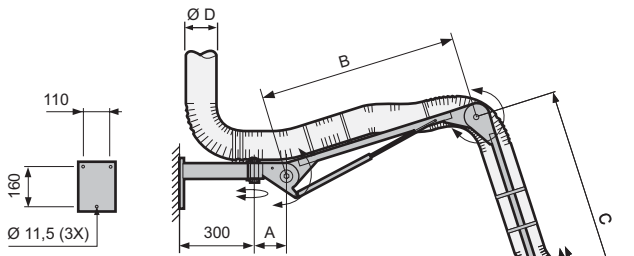

R EX / R EXH	A (mm)	B (mm)	C (mm)	D (mm)	Working radius* (mm)	Maximum radius (mm)
1500	120	510	760	900	1150	1690
2000	120	740	990	1130	1600	2150
3000	120	1140	1390	1530	2600	2950
4000	1100	1140	1390	1590	3600	3930

* Recommended mounting height of 2.0 m and a working height of 750 mm.

Hood EX	Ø A (mm)	Ø B (mm)
75	72	250
100	98	250
125	122	250
160	156	300
200	199	350

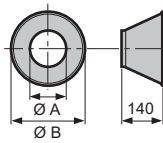

Ø E (mm)	Ø E2 (mm)
75	250
100	250
125	250
160	300
200	350

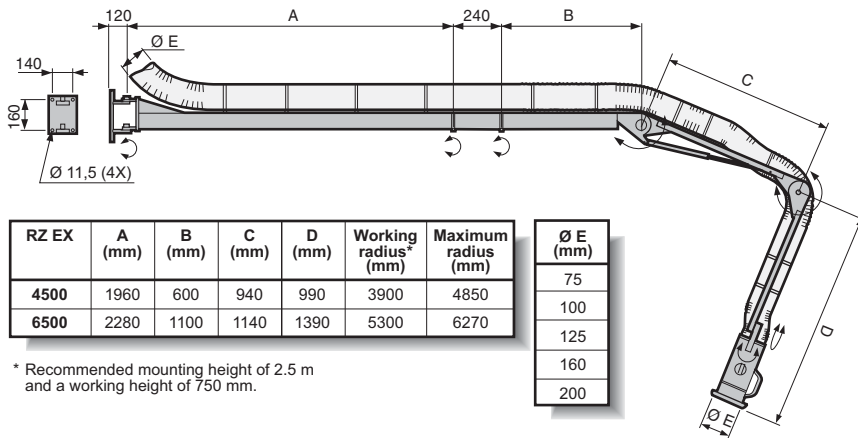
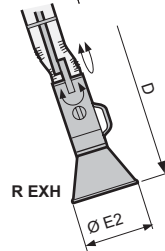

RZ EX	A (mm)	B (mm)	C (mm)	D (mm)	Working radius* (mm)	Maximum radius (mm)
4500	1960	600	940	990	3900	4850
6500	2280	1100	1140	1390	5300	6270

* Recommended mounting height of 2.5 m and a working height of 750 mm.

Ø E (mm)
75
100
125
160
200

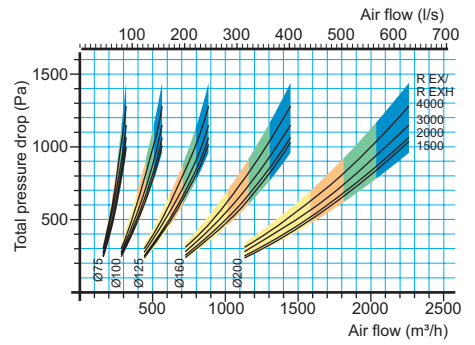

The black line shows the pressure drop for the arm when in the same position as in the design above. The area in the diagram shows the pressure drop at normal use. The field's tints show air velocity in the extractor according to below.

- (yellow) 10-14 m/s
- (orange) 14-16 m/s
- (green) 16-18 m/s
- (blue) 18-20 m/s

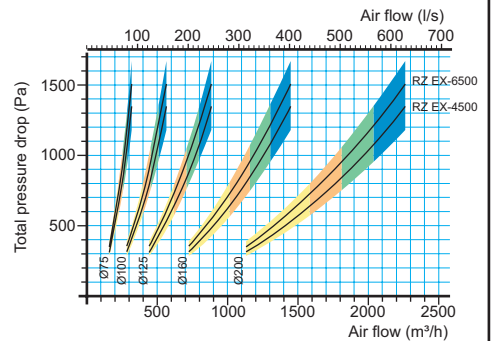

Delivery

The arm is assembled mounted and tested. Every arm has a unique manufacturing number.

Manufacture

Manufactured in accordance with relevant sections of following standards or regulatory documents: EN 1127-1:1997, EN 13463-1:2001, CENELEC report TR50404, according to the terms in the ATEX directive 94/9/EC.

Technical data

Data ATEX

Equipment group.....	II
Equipment category.....	2
Zone, gas.....	1
Zone, dust.....	21
Surrounding temperature.....	0 - 60°C
Hose dimensions.....	75, 100, 125, 160, 200 mm

Material

Arm system

R EX	Lacquered steel, conductive powder coating in metallic grey paint. R < 10 ⁸ Ω.
R EXH	Stainless steel, SS EN 2343
RZ EX	Lacquered steel, conductive powder coating in metallic grey paint. R < 10 ⁸ Ω.
Hose	Anti-static polyester-polyurethane. R < 10 ⁸ Ω.

Suction nozzle

R EX / RZ EX	Lacquered steel, conductive powder coating in metallic grey paint. R < 10 ⁸ Ω.
R EXH	Stainless steel SS EN 2348

FUMEX®

Verkstadsvägen 2, 931 61 SKELLEFTEÅ, Sweden
Skellefteå: Tel. +46 910-361 80, Fax +46 910-130 22
www.fumex.se info@fumex.se