

# PIPE/FAN CONNECTOR



This coupling collar serves for connecting of a fan with a circular duct in the same diameter and at the same time it is of service for decrease of a transfer of vibrations from a fan to duct. The advantage of this type of connection is a possibility to take the fan out of the air distribution system at any time by reason of some revision, repair or exchange.

## CONSTRUCTION

The collar is made of galvanized steel sheet, sticked with a foam polyethylene sealing of a thickness 6 mm on its inward side. For a fixation of the collar serves two screws M6 stepped into the ends of the collar: screws as well as nuts are parts of the product. The general constructional settlement of a collar guarantees a high strenght of the construction.

## OPERATION CONDITIONS

The Pipe\fan connector is destined for operation in a standard environment with ambient temperature up to 60°C, for transportation of clean air free of coarse dust, grease, chemical vapours and other impurities.

## INSTALLATION

Wind a collar round a collet of a fan and a connecting duct, between them must be an interspace around 2 mm. Clep a screwhead to the cutting on the end of a collar. Wear both screws out in turns so that the connection is hard-set and tight enough and that any deformation of a collar cannot occur.

## Ordering code:

Product: **Pipe/fan Connector**  
 Diameter: 200  
 Code: **DMK200**

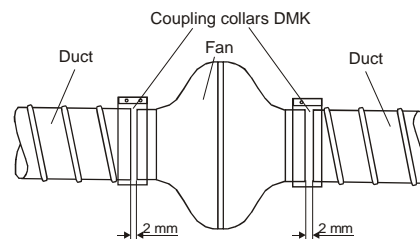

Type	ØD1 mm	Sheet mm	Weight kg
DMK100	100	0.55	0.14
DMK125	125	0.55	0.16
DMK150	150	0.55	0.19
DMK160	160	0.55	0.20
DMK180	180	0.55	0.22
DMK200	200	0.55	0.23
DMK224	224	0.55	0.24
DMK250	250	0.55	0.27
DMK315	315	0.55	0.32
DMK355	355	0.55	0.40
DMK400	400	0.55	0.45

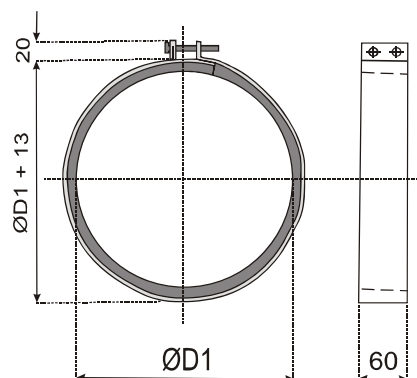

3.22

Pipe / fan  
connector

The information contained in this brochure was current on the publication date (01-2004). The Company reserves the right to make changes in details at any time without prior notice. In order to avoid misunderstandings, any interested party is advised to contact the Company checking for any changes in materials and/or information after this brochure was published.

Version 2005 WWW.DECINTERNATIONAL.COM