

Flexit S12 X

Art.no.	Type
14535	S12 XER 400V
14536	S12 XEL 400V
14537	S12 XWR
14538	S12 XLW



CI 500 Control Panel included in all units.

	S12 XW	S12 XE
Rated voltage:	230 V	400 V
Fuse:	1 x 10 A	3 x 16 A
Rated current, total:	6 A	14 A
Rated power, total:	1 100 W	7 100 W
Rated power, electric battery:		6 000 W
Rated power, fans:	2 x 485 W	2 x 485 W
Rated power, preheating:		
Fan type:	B-wheel	B-wheel
Fan motor control:	EC-control system	EC-control system
Max. fan speed:	3 580 rpm	3 580 rpm
Filter type (SUP/EXTR):	F 7	F 7
Filter dimension (W x H x D):	2 x (592 x 294 x 250 mm)	2 x (592 x 294 x 250 mm)
Numbers of bags:	12	12
Weight:	185 kg	185 kg
Duct connection:	Ø 250 mm	Ø 250 mm
Height:	1 380 mm	1 380 mm
Width:	1 250 mm	1 250 mm
Depth:	700 mm	700 mm

Flexit S12 X

Accessories



Bag Filter
Art.no. Type
12324 F7



Closing Air Damper w/ Spring Return
Art.no. Type
14485 Ø250 w/Spring Return
14476 Ø250 on/off



3-way Valve
Art.no. Type
56232 KVS 1.6 3-way
56432 KVS 1,6 2-way
57228 KVS 2,5 3-way
56433 KVS 2,5 2-way
56072 fittings KVS 2,5



Motor 3-way Valve
Art.no. Type
56234 0-10V



SP440 CO₂
Art.no.
09359



SP 435 Motion Detector
Art.no.
09358



SP 450 Motion Detector
Art.no.
09390



CC 1050 Pressure Sensor
Art.no.
09367



SP 445 Smoke Detector
Art.no.
09362

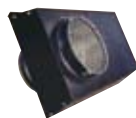

Combi. Unit
Art.no. Type
14328 2xØ250mm, black
14331 2xØ315mm, black

Accessories, automatic CS1000



CC 1060 GSM-card
Art.no. 09370

Modem, antenna with cable and magnet holder, transformer and cable 0,8 m.

CC 1061 GSM-equipment
Art.no. 09371



CC 1062 LON-card
Art.no. 09372



CC 1063 WEB/OPC-card
Art.no. 09373



CC 1040 Room Sensor
Art.no. 09368



CC 1041 Outdoor Air Sensor
Art.no. 09369



SP430 Pressure Sensor
Art.no. 09357



Press Button
Art.no. 09364

Flexit S12 X

S12 XWR

System drawing, water-based heating

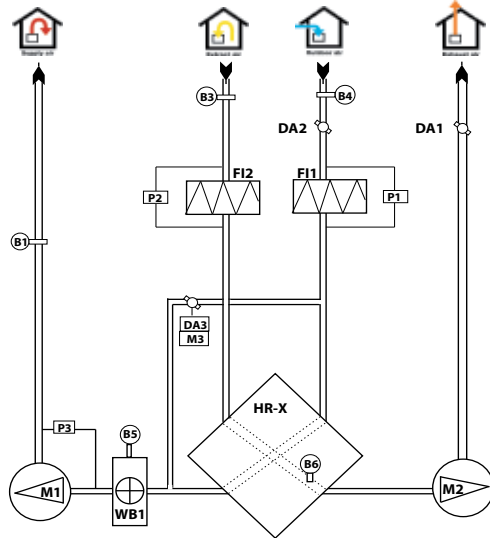

- | | | | |
|------|--|-----|---|
| M1 | Supply air fan | B5 | Temperature sensor, water battery (frost relay) |
| M2 | Extract air fan | B6 | Temperature sensor, thermoguard |
| M3 | Air damper motor, exchanger | DA1 | Air damper, exhaust air (not standard) |
| F1 | Supply air filter | DA2 | Air damper, outdoor air (not standard) |
| F2 | Extract air filter | DA3 | Air damper, heat exchanger |
| HR-X | Cross heat exchanger | WB1 | Water Battery |
| P1 | Pressure guard, supply air filter | | |
| P2 | Pressure guard, extract air filter | | |
| B1 | Temperature sensor, supply air | | |
| B3 | Temperature sensor, extract air (not standard) | | |
| B4 | Temperature sensor, outdoor air (not standard) | | |

S12 XER

System drawing, electric heating

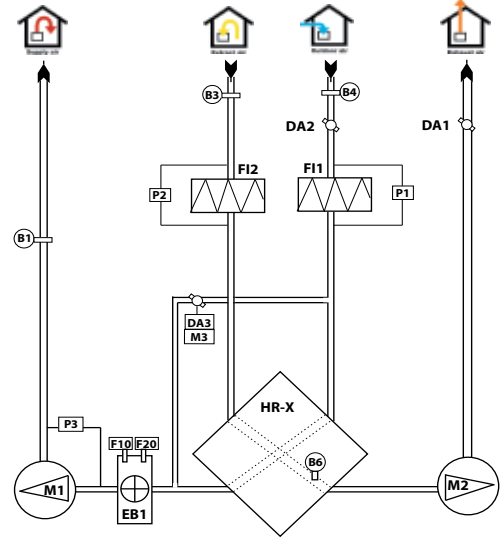

- | | | | |
|------|--------------------------------------|-----|--|
| M1 | Supply air fan | B3 | Temperature sensor, extract air (not standard) |
| M2 | Extract air fan | B4 | Temperature sensor, outdoor air (not standard) |
| M3 | Air damper motor, exchanger | B6 | Temperature sensor thermoguard |
| F1 | Supply air filter | DA1 | Air damper, exhaust air (not standard) |
| F2 | Extract air filter | DA2 | Air damper, outdoor air (not standard) |
| HR-X | Cross heat exchanger | DA3 | Air damper, heat exchanger |
| F10 | Overheating thermostat, manual reset | EB1 | Electric Battery |
| F20 | Overheating thermostat | | |
| P1 | Pressure guard, supply air filter | | |
| P2 | Pressure guard, extract air filter | | |
| P3 | Pressure relay, supply air fan | | |
| B1 | Temperature sensor, supply air | | |

Dimensioned drawing

Dimensions in mm

- cross heat exchanger model, right

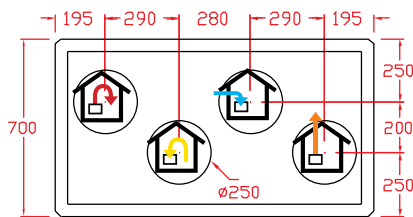
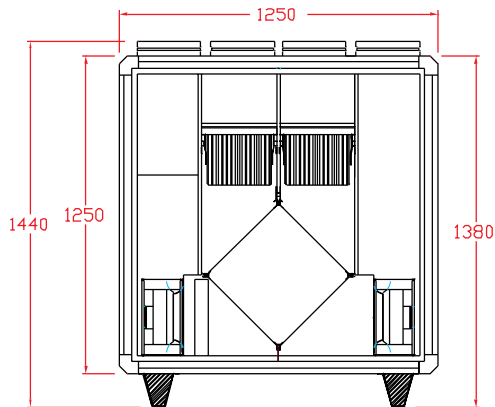

Front

Dimensioned drawing

Dimensions in mm

- cross heat exchanger model, left

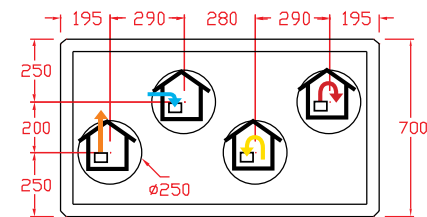
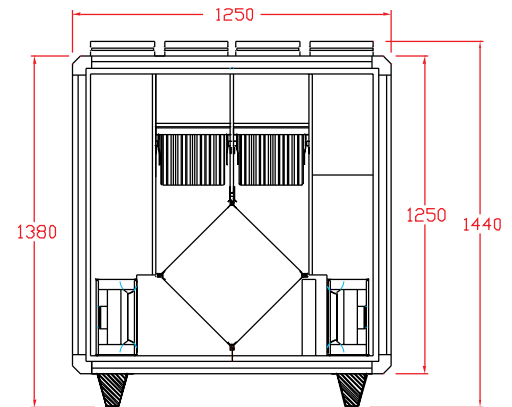

Front

Flexit S12 X

Capacity Diagram S12 X EC W/E (measured with F7 filter)

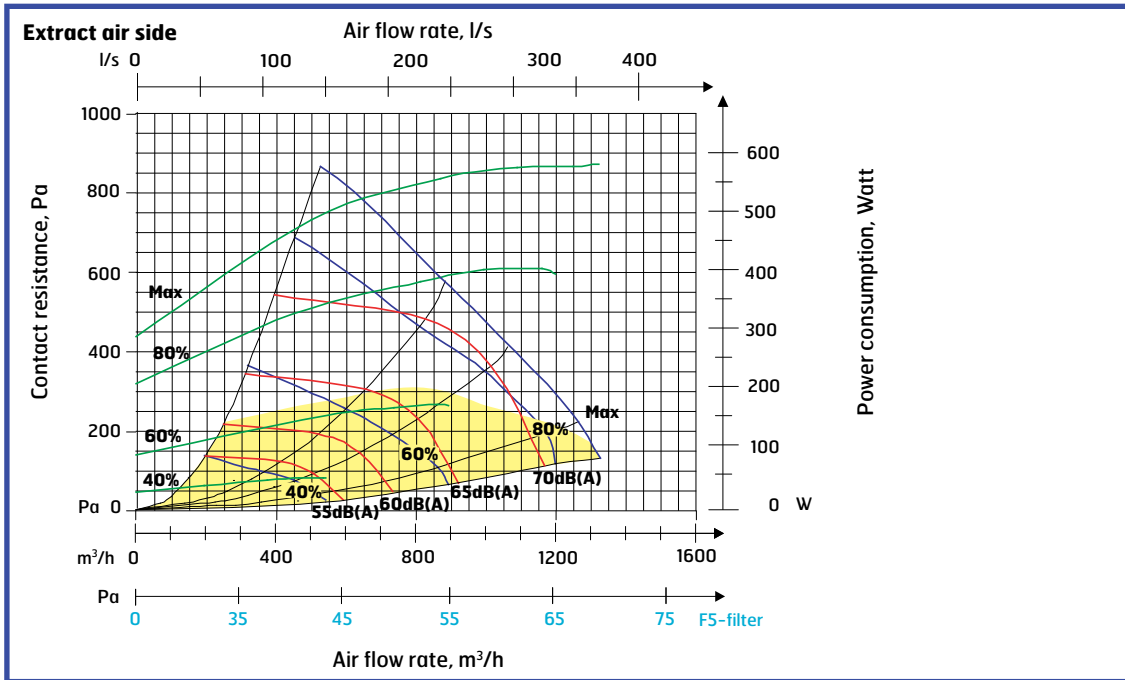
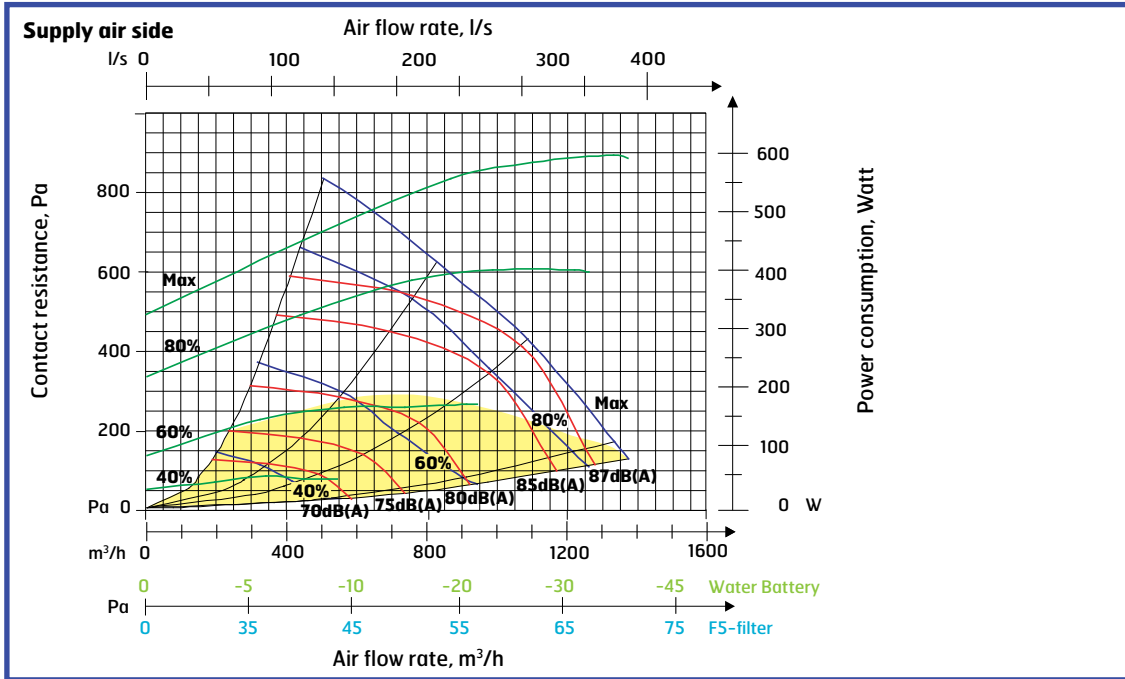

Yellow field: SFP < 1.25 per fan

$$SFP = \frac{P}{V} \text{ [kW/m}^3\text{/s]} = \text{J/m}^3$$

Sound data is given at sound power level LwA in the capacity diagrams and is corrected with the table below for the various octave bands and is corrected with the table below for the various octave bands and total LwA. Radiated noise is calculated by taking the noise value from the supply air table and deducting the total value from the correction factor table.

Supply air data is measured in accordance with ISO 5136, the in-duct method. Radiated noise is measured in accordance with ISO 9614-2. Bruel & Kjaer measuring equipment, type 2260.

Correction factor for Lw									
Hz	63	125	250	500	1000	2000	4000	8000	Total LwA
Supply air	-3	-2	-1	0	-8	-10	-16	-30	
Extract air	11	6	-1	0	-8	-15	-27	-40	
Radiated	-40	-41	-37	-45	-43	-42	-45	-54	-36,6

Blue curves: Air capacity at various capacity settings in Volt.

Green curves: Supply air fan power consumption at various capacity settings.

Red curves: Sound power level LwA, cf. correction table.

Light blue correction axe: Pressure increase using an EU-5 filter.

Light green correction axe: Pressure increase using water battery.