

LOCAL EXTRACTOR



RX

1500, 2000,
3000, 4000
with gas spring

Local extractor for e.g. welding worksites where great flexibility and efficient extraction are important



White design



Suction nozzle with
360° swivel

The FUMEX local extractor RX, with lengths 1.5, 2, 3 and 4 m, is equipped with a gas spring that balances the dead weight of the arm. For this reason, the RX is extremely easy to handle at the same time as it stays without rebounding when positioned, even in the outer positions. The suction nozzle incorporates a swivel function and may be rotated 360° and moved to a 90° angle. This allows the suction nozzle to be positioned as required.

FUMEX always designs its local extractors with supporting arms on the outside, which ensures a natural and undisturbed air flow. In addition, the pressure drop will be low and there is hardly any risk of ducts being blocked. The RX may also be equipped with a flat screen hood for even greater efficiency. A conical hood, with or without halogen light, is also available.

The smooth inside of the suction duct makes the RX very easy to clean. Adjustments of joints as well as main-tenance can easily be taken care of with hand tools from the outside.

The FUMEX RX is easy to install and can be delivered with brackets for ceiling, floor or bench mounting.

Fumex also offers a range of fans, accessories, automatic control devices and filters for our local extractors.

FUMEX®

LOCAL EXTRACTOR

Pure advantage

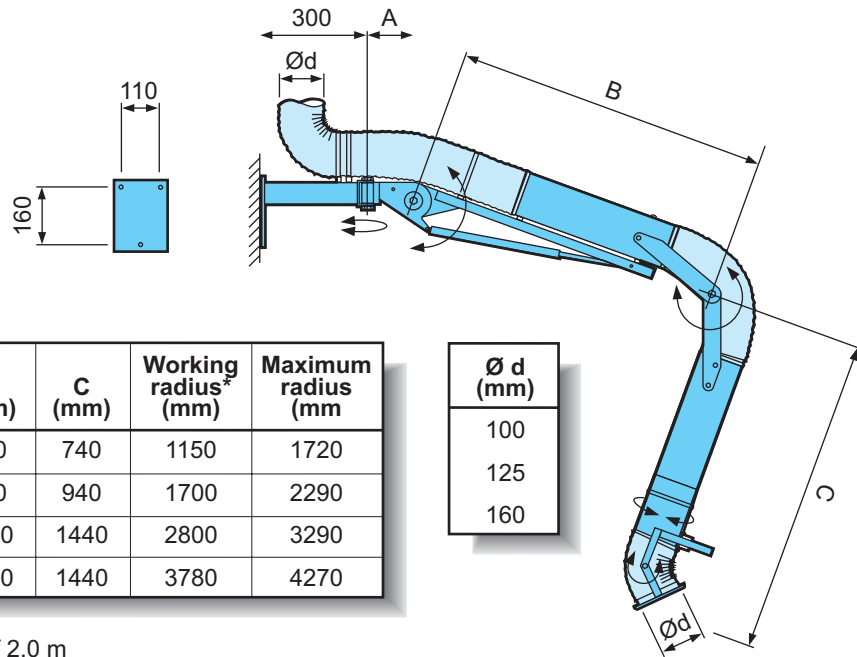

* At a mounting height of 2.0 m and a working height of 750 mm

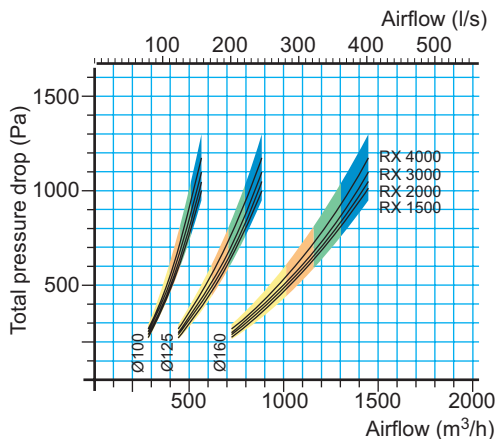

The black line shows the pressure drop for the extractor when in the same position as the arm on the design above. The area in the diagramme shows the pressure drop at normal use. The different tints show air velocity in the extractor according to the code below. Recommended transport velocity for welding fumes is 18m/s.

- (yellow) 10-14 m/s
- (orange) 14-16 m/s
- (green) 16-18 m/s
- (blue) 18-20 m/s

Hose

Made of spring steel coil completely embedded in PVC-coated polyamide fabric.

For other hose qualities, contact FUMEX.

Tube

Made of powder coated, rounded sheet steel

Delivery

For easy installation, the arm is delivered fully assembled including bracket for wall mounting. The arm can also be delivered in white coating and tubes in stainless steel. Accessories include brackets for ceiling, floor and table mounting as well as flat screen hood or conical hood with or without halogen light.

Hose

Qualities Non-inflammable, suitable for welding fumes and flue gas.

Temperature range -10°C to +90° C

Gas spring

Working temperature + 20° C

Temperature range -40°C to +90° C

Other information

Surface treatment of metal components Powder coating

Weight
 RX 1500: 9 kg
 RX 2000: 16 kg
 RX 3000: 21 kg
 RX 4000: 24 kg

FUMEX®