

# INLINE BACKDRAUGHT SHUTTER

## INLINE BACKDRAUGHT SHUTTER TYPE BDSI.

The Inline backdraught shutter type **BDSI** is used to preventing the reverse of air-flow in circular duct systems.



### CONSTRUCTION

The casing of the shutter is made of galvanized steel sheet. The blades are made of aluminium, shaft and spring are made of stainless steel. The inner rubber seal is used for better tightness and for noise reduction. The outer foam sealing strip provides good tightening and fixing of the **BDSI** inside the duct. The nominal dimensions correspond with the DIN 24145. Production range and main dimensions see the table.

Article code: **BDSIØ**

### INSTALLATION

The **BDSI** has to be installed in horizontal position. The shaft axis must be positioned vertically. The **BDSI** must be inserted fully into the duct.

### OPERATION CONDITIONS

The shutter is destined for operation in a standard environment with ambient temperature up to 60°C, for transportation of clean air free of coarse dust, grease, chemical vapours and other impurities.

The **BDSI** is sold by the piece.

### PRESSURE DROP CHART

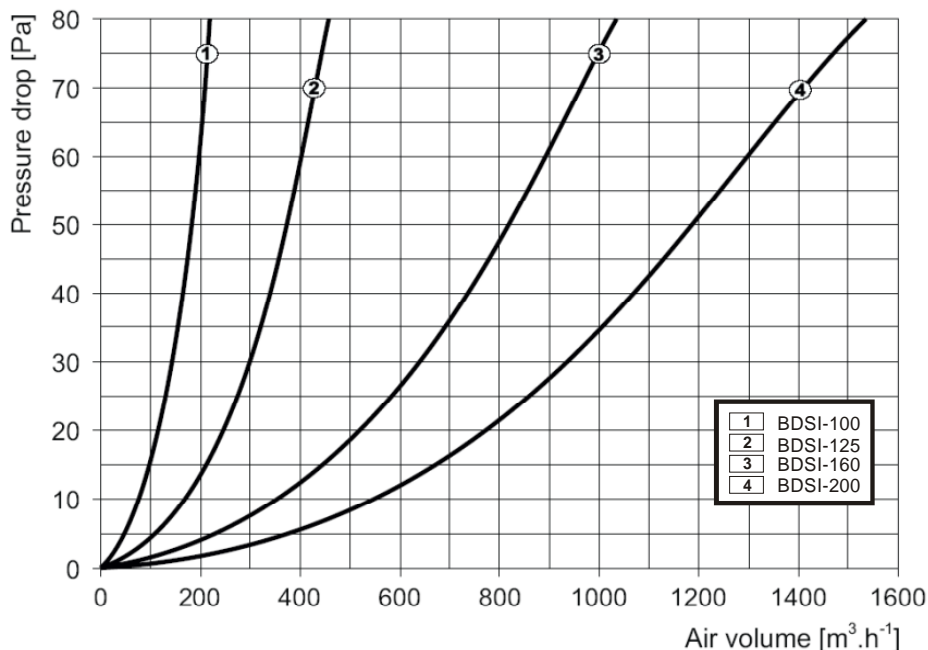

The information contained in this brochure was current on the publication date. The Company reserves the right to make changes in details at any time without prior notice. In order to avoid misunderstandings, any interested party is advised to contact the Company checking for any changes in materials and/or information after this brochure was published.

Version 2005 [www.decinternational.com](http://www.decinternational.com)

# INLINE BACKDRAUGHT SHUTTER

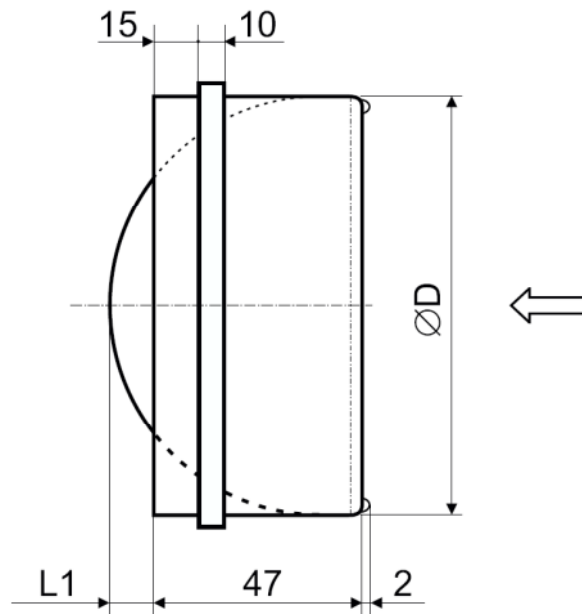

Type	ØD (mm)	L1 (mm)	Weight (kg)
BSDI-100	100	8	0.15
BSDI-125	125	17	0.20
BSDI-150	150	32	0.30
BSDI-160	160	37	0.40
BSDI-200	200	56	0.70



The information contained in this brochure was current on the publication date. The Company reserves the right to make changes in details at any time without prior notice. In order to avoid misunderstandings, any interested party is advised to contact the Company checking for any changes in materials and/or information after this brochure was published.

Version 2005 [www.decinternational.com](http://www.decinternational.com)