



AD 120 B

FUNCTION

The AD 120 B is an adsorption dehumidifier with a silica gel rotor as standard. Process air is drawn into the dehumidifier and through the rotor, which slowly turns between two sections in the dehumidifier. The silica gel rotor absorbs the moisture from the air in the drying section. This moisture is removed again by blowing hot air through the rotor in the regeneration section. The process air leaves the dehumidifier as dry air and the moisture is led out of the room through the regenerated air outlet. Dehumidification and regeneration are going on continuously until the desired relative humidity is obtained.

The silica gel rotor, drive motor, heating elements, air fans and filters are fully installed in the cabinet.

Simply connect the power supply and necessary air hoses on site and the unit is ready for immediate operation.

FEATURES

- Cabinet manufactured in stainless steel AISI 304
- Compact and low weight
- Built-in handles for ease of carrying and stacking
- Built-in hour run meter
- High capacity at low temperatures and low levels of relative humidity
- Deep drying at reduced process air flow
- Available pressure for connection to external ductwork
- Optional hygostat and dew point controller as accessories
- Easy internal access for servicing and maintenance
- High performance washable silica gel desiccant rotor

APPLICATIONS

The AD adsorption dehumidifier is designed for drying out both new and water damaged buildings and for room air dehumidification, dry air storage applications as well as water works and pumping stations.

CONTROL

The AD adsorption dehumidifiers can be operated either in MAN for continuous operation or HYG for operation with connected hygostat. All units are prepared for connection of optional hygostat or dew point controller.



TECHNICAL DATA

Model		AD 120 B
Dehumidification capacity at 20°C/60% RH	kg/h	0.45
Operating range - temperature	°C	-15 – +35
Operating range - humidity	% RH	0-100
Nom. air volume, dry air	m ³ /h	120
Nom. regenerated air volume	m ³ /h	35
Voltage	V	230/1N+PE
Power consumption	kW	0.78
Power consumption electric heater, nominal	W	690
External pressure, dry air	Pa	50
External fuse	A	10
Weight	kg	12
Dry air outlet/duct	Ø mm	100
Regenerated air outlet/duct	Ø mm	50

Deeper drying and higher external pressure are obtained by reduced process air flow (e.g. by use of a damper or another resistance in the regenerated air outlet).

DIMENSIONS AND AIR FLOWS

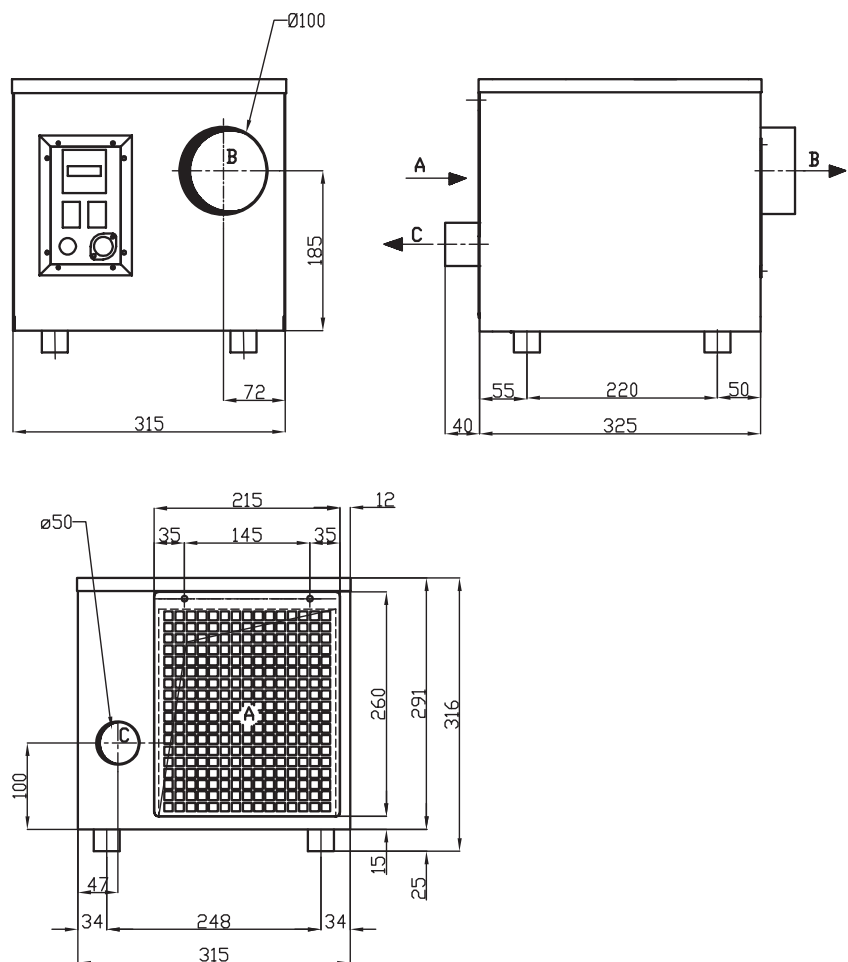

- A: Regenerated/process air inlet
- B: Dry air outlet
- C: Regenerated air outlet

ACCESSORIES

- Hygrostat
- Hygrostat and dew point controller
- Back plate
- Cableholder
- (see separate data sheet for accessories)

All dimensions are in mm.



AD 240 B

FUNCTION

The AD 240 B is an adsorption dehumidifier with a silica gel rotor as standard. Process air is drawn into the dehumidifier and through the rotor, which slowly turns between two sections in the dehumidifier. The silica gel rotor absorbs the moisture from the air in the drying section. This moisture is removed again by blowing hot air through the rotor in the regeneration section. The process air leaves the dehumidifier as dry air and the moisture is led out of the room through the regenerated air outlet. Dehumidification and regeneration are going on continuously until the desired relative humidity is obtained.

The silica gel rotor, drive motor, heating elements, air fans and filters are fully installed in the cabinet.

Simply connect the power supply and necessary air hoses on site and the unit is ready for immediate operation.

FEATURES

- Cabinet manufactured in stainless steel AISI 304
- Compact and low weight
- Built-in handles for ease of carrying and stacking
- Built-in hour run meter
- High capacity at low temperatures and low levels of relative humidity
- Deep drying at reduced process air flow
- Available pressure for connection to external ductwork
- Optional hygostat and dew point controller as accessories
- Easy internal access for servicing and maintenance
- High performance washable silica gel desiccant rotor

APPLICATIONS

The AD adsorption dehumidifier is designed for drying out both new and water damaged buildings and for room air dehumidification, dry air storage applications as well as water works and pumping stations.

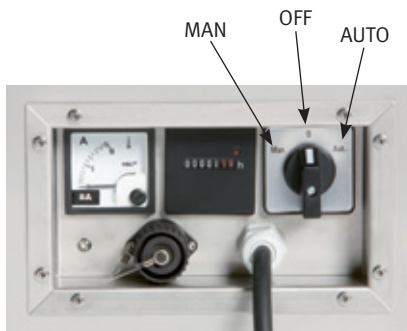

CONTROL

The AD adsorption dehumidifiers can be operated either in MAN for continuous operation or AUTO for operation with connected hygostat. All units are prepared for connection of optional hygostat or dew point controller.

TECHNICAL DATA

Model		AD 240 B
Dehumidification capacity at 20°C/60% RH	kg/h	0.80
Operating range - temperature	°C	-15 – +35
Operating range - humidity	% RH	0-100
Nom. air volume, dry air	m ³ /h	240
Nom. regenerated air volume	m ³ /h	45
Voltage	V	230/1N+PE
Power consumption	kW	1.05
Power consumption electric heater, nominal	W	920
External pressure, dry air	Pa	60
External fuse	A	10
Weight	kg	15
Dry air outlet/duct	Ø mm	100
Regenerated air outlet/duct	Ø mm	80

Deeper drying and higher external pressure are obtained by reduced process air flow (e.g. by use of a damper or another resistance in the regenerated air outlet).

DIMENSIONS AND AIR FLOWS

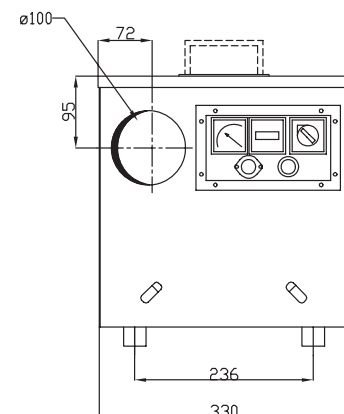
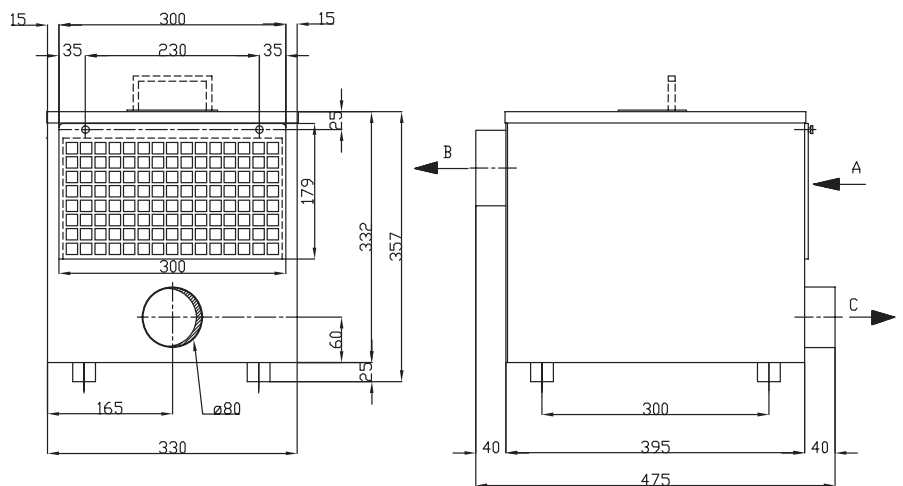

- A: Regenerated/process air inlet
- B: Dry air outlet
- C: Regenerated air outlet

ACCESSORIES

- Hygrostat
- Hygrostat and dew point controller
- Back plate
- Cableholder
- (see separate data sheet for accessories)

All dimensions are in mm.



AD 290 B

FUNCTION

The AD 290 B is an adsorption dehumidifier with a silica gel rotor as standard. Process air is drawn into the dehumidifier and through the rotor, which slowly turns between two sections in the dehumidifier. The silica gel rotor absorbs the moisture from the air in the drying section. This moisture is removed again by blowing hot air through the rotor in the regeneration section. The process air leaves the dehumidifier as dry air and the moisture is led out of the room through the regenerated air outlet. Dehumidification and regeneration are going on continuously until the desired relative humidity is obtained.

The silica gel rotor, drive motor, heating elements, air fans and filters are fully installed in the cabinet.

Simply connect the power supply and necessary air hoses on site and the unit is ready for immediate operation.

FEATURES

- Cabinet manufactured in stainless steel AISI 304
- Compact and low weight
- Built-in handles for ease of carrying and stacking
- Built-in hour run meter
- High capacity at low temperatures and low levels of relative humidity
- Deep drying at reduced process air flow
- Available pressure for connection to external ductwork
- Optional hygostat and dew point controller as accessories
- Easy internal access for servicing and maintenance
- High performance washable silica gel desiccant rotor

APPLICATIONS

The AD adsorption dehumidifier is designed for drying out both new and water damaged buildings and for room air dehumidification, dry air storage applications as well as water works and pumping stations.

CONTROL

The AD adsorption dehumidifiers can be operated either in MAN for continuous operation or AUTO for operation with connected hygostat. All units are prepared for connection of optional hygostat or dew point controller.

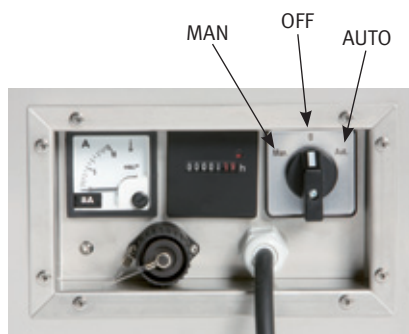

TECHNICAL DATA

Model		AD 290 B
Dehumidification capacity at 20°C/60% RH	kg/h	1.10
Operating range - temperature	°C	-15 – +35
Operating range - humidity	% RH	0-100
Nom. air volume, dry air	m ³ /h	290
Nom. regenerated air volume	m ³ /h	65
Voltage	V	230/1N+PE
Power consumption	kW	1.64
Power consumption electric heater, nominal	W	690
External pressure, dry air	Pa	50
External fuse	A	10
Weight	kg	17
Dry air outlet/duct	Ø mm	100
Regenerated air outlet/duct	Ø mm	80

Deeper drying and higher external pressure are obtained by reduced process air flow (e.g. by use of a damper or another resistance in the regenerated air outlet).

DIMENSIONS AND AIR FLOWS

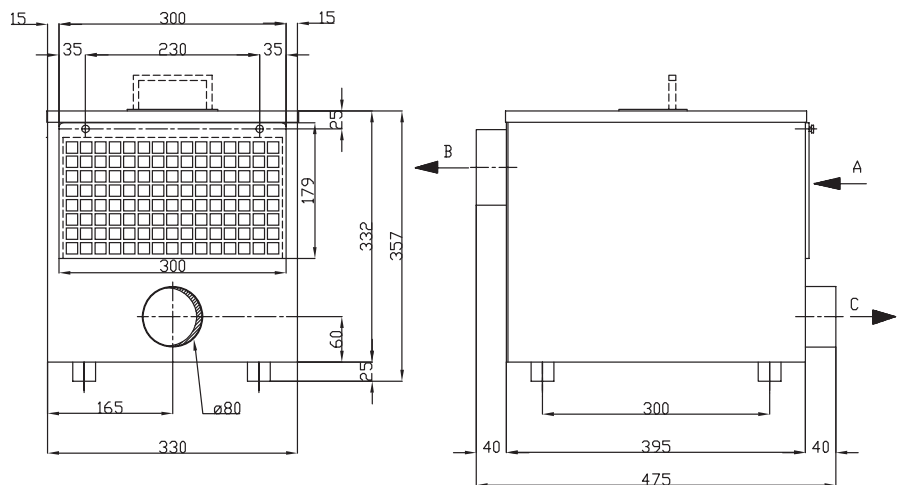

- A: Regenerated/process air inlet
- B: Dry air outlet
- C: Regenerated air outlet

ACCESSORIES

- Hygrostat
- Hygrostat and dew point controller
- Back plate
- Cableholder
- (see separate data sheet for accessories)

All dimensions are in mm.



AD 400 B

FUNCTION

The AD 400 B is an adsorption dehumidifier with a silica gel rotor as standard. Process air is drawn into the dehumidifier and through the rotor, which slowly turns between two sections in the dehumidifier. The silica gel rotor absorbs the moisture from the air in the drying section. This moisture is removed again by blowing hot air through the rotor in the regeneration section. The process air leaves the dehumidifier as dry air and the moisture is led out of the room through the regenerated air outlet. Dehumidification and regeneration are going on continuously until the desired relative humidity is obtained.

The silica gel rotor, drive motor, heating elements, air fans and filters are fully installed in the cabinet.

Simply connect the power supply and necessary air hoses on site and the unit is ready for immediate operation.

FEATURES

- Cabinet manufactured in stainless steel AISI 304
- Compact and low weight
- Built-in handles for ease of carrying and stacking
- Built-in hour run meter
- High capacity at low temperatures and low levels of relative humidity
- Deep drying at reduced process air flow
- Available pressure for connection to external ductwork
- Optional hygostat and dew point controller as accessories
- Easy internal access for servicing and maintenance
- High performance washable silica gel desiccant rotor

APPLICATIONS

The AD adsorption dehumidifier is designed for drying out both new and water damaged buildings and for room air dehumidification, dry air storage applications as well as water works and pumping stations.

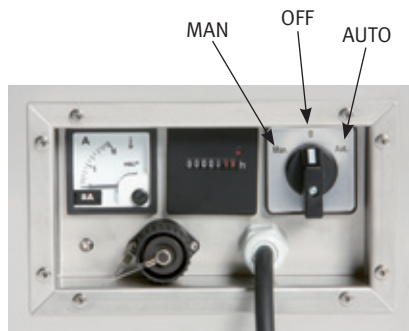

CONTROL

The AD adsorption dehumidifiers can be operated either in MAN for continuous operation or AUTO for operation with connected hygostat. All units are prepared for connection of optional hygostat or dew point controller.

TECHNICAL DATA

Model		AD 400 B
Dehumidification capacity at 20°C/60% RH	kg/h	1.40
Operating range - temperature	°C	-15 – +35
Operating range - humidity	% RH	0-100
Nom. air volume, dry air	m ³ /h	400
Nom. regenerated air volume	m ³ /h	85
Voltage	V	230/1N+PE
Power consumption	kW	2.10
Power consumption electric heater, nominal	W	1840
External pressure, dry air	Pa	50
External fuse	A	10
Weight	kg	27
Dry air outlet/duct	Ø mm	125
Regenerated air outlet/duct	Ø mm	80

Deeper drying and higher external pressure are obtained by reduced process air flow (e.g. by use of a damper or another resistance in the regenerated air outlet).

DIMENSIONS AND AIR FLOWS

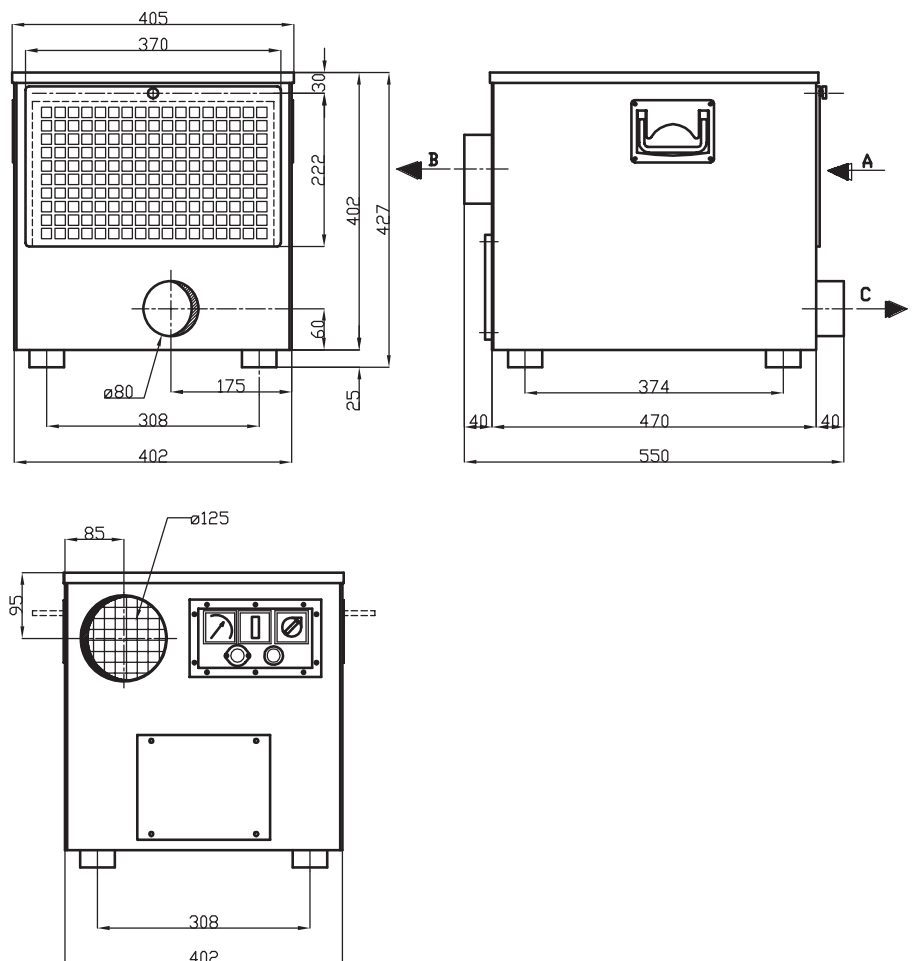

ACCESSORIES

- Hygrostat
- Hygrostat and dew point controller
- Back plate
- Cableholder
- (see separate data sheet for accessories)

- A: Regenerated/process air inlet
- B: Dry air outlet
- C: Regenerated air outlet

All dimensions are in mm.

ACCESSORIES FOR AD series B ADSORPTION DEHUMIDIFIERS

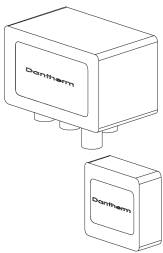
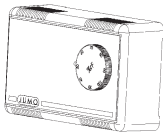
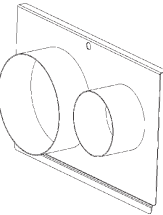
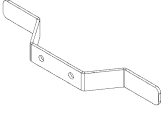
Illustration	Accessory	Description	AD type	Dantherm No.										
	Hygrostat and dew point controller DH 24	<p>Combines an electronic hygrostat and dew point controller in one and the same product. DH 24 consists of a connection box with humidity and temperature sensors and a separate control panel.</p> <p>The connection box must be placed close to the dehumidifier, whereas the control panel can be placed at a distance of up to 500 m from the connection box – connected by a cable. The control panel displays temperature, RH value and dew point temperature. When the set value has been reached, an acoustic signal will be heard.</p> <p>DH 24 is an on/off control for both RH value and dew point, which makes it extremely suitable for water works, where it is important to avoid condensation on cold surfaces. It is also recommended for controlling the relative humidity in dry air storage rooms and crawl spaces.</p> <table border="1" style="margin-left: auto; margin-right: auto;"> <tr> <td>Operating range – relative humidity</td> <td>5-95% RH</td> </tr> <tr> <td>Operating range – temperature</td> <td>-5° to +45°C</td> </tr> <tr> <td>Protection class</td> <td>IP 54</td> </tr> <tr> <td>Voltage</td> <td>230 V/50 Hz</td> </tr> <tr> <td>Fuse</td> <td>10 A</td> </tr> </table>	Operating range – relative humidity	5-95% RH	Operating range – temperature	-5° to +45°C	Protection class	IP 54	Voltage	230 V/50 Hz	Fuse	10 A	All	351037
Operating range – relative humidity	5-95% RH													
Operating range – temperature	-5° to +45°C													
Protection class	IP 54													
Voltage	230 V/50 Hz													
Fuse	10 A													
	Hygrostat	<p>The dehumidifier is designed for connection to an external hygrostat which is used when the maintenance of a certain RH value is required.</p> <table border="1" style="margin-left: auto; margin-right: auto;"> <tr> <td>Operating range – relative humidity</td> <td>30-100% RH</td> </tr> <tr> <td>Operating range – temperature</td> <td>0 to 60°C</td> </tr> <tr> <td>Protection class</td> <td>IP 20</td> </tr> <tr> <td>Voltage</td> <td>230 V/50 Hz</td> </tr> <tr> <td>Fuse</td> <td>10 A</td> </tr> </table>	Operating range – relative humidity	30-100% RH	Operating range – temperature	0 to 60°C	Protection class	IP 20	Voltage	230 V/50 Hz	Fuse	10 A	All	351036
Operating range – relative humidity	30-100% RH													
Operating range – temperature	0 to 60°C													
Protection class	IP 20													
Voltage	230 V/50 Hz													
Fuse	10 A													
	Back plate	<p>For standard operations minor sub pressure may occur in the room where the dehumidifier is located, because the regeneration air is led away from the room via duct or hose. This may in some cases not be desirable and in such cases the back plate with two stubs for process air, in and regeneration air, in may be used. By taking in regeneration air from the outside a pressure stabilized system may be established.</p> <p>The back plate is available in three sizes.</p>	AD120B AD240B AD290B AD400B	351038 351034 351034 351039										
	Cable holder	Used if winding of the electrical cable is required. To be mounted on the rear side of the dehumidifier by means of two ready-mounted screws. Box containing two pieces	All	351035										