

**PLENUM FOR FIXED SLOT DIFFUSER
TP100 • TP700**

Installation dimensions

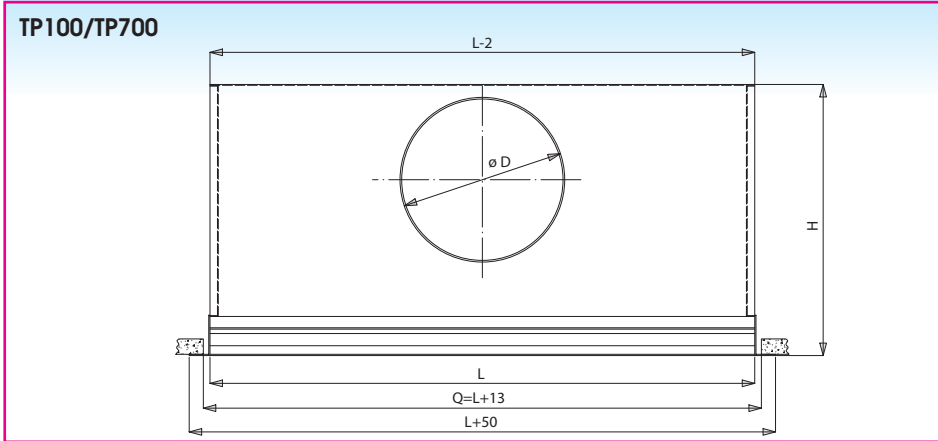

H = 325mm (if TE600 is mounted with TP100)

H = 365mm (if TE700 is mounted with TP700)

L	300	600	900	1200	300	600	900	1200	300	600	900	1200	
ϕD	125	125	160	200	125	160	200	250	160	200	250	250	
	4 SLOTS				5 SLOTS				6 SLOTS				
L	300	600	900	1200	300	600	900	1200	300	600	900	1200	
ϕD	200	250	250	250	200	250	250	250	200	250	250	250	
	7 SLOTS				8 SLOTS								
L	300	600	900	1200	300	600	900	1200					
ϕD	200	250	250	250	200	250	250	250					

How to order

TP100, not insulated and without damper for TE601, L = 900 mm.

T	P	1	0	1	-	-	0	1	2	5	1	2	0	0
---	---	---	---	---	---	---	---	---	---	---	---	---	---	---

- Spigot diameter Slot length (mm)
- : non insulated plenum
- G : internally insulated plenum
- H : double sided insulated plenum
- 1: number of slots, supply direction
AT THE RIGHT, with air entry at the right
- 0: number of slots, supply direction
AT THE LEFT, with air entry at the right
- 1: without damper in inlet spigot (for TE600)
- 2: with damper in inlet spigot (for TE600)
- 3: without damper in inlet spigot, provided with mounting straps (for TE600)
- 4: with damper in inlet spigot, provided with mounting straps (for TE600)
- 7: bevelled filterframe without damper in inlet spigot (for TE700)
- 8: bevelled filterframe with damper in inlet spigot (for TE700)
- 9: bevelled filterframe without damper in inlet spigot, provided with mounting straps (for TE700)