

SUPPLY AIR VALVE DVKR

TECHNICAL DATA

PRODUCT PROPERTIES

- Available in diameter 100, 125, 150/160 and 200 mm.
- Manufactured from white polypropylene (Ral 9010).
- The valve is difficult to ignite (Will not burn with open flame).
- The valve material has a melting point between 150-180 °C.
- The valve resist temperatures up to 110 °C without deformation.
- High valve body improving air flow/less noise.
- Closed disc.
- No leakage between valve body and connection bush.
- Connection bush also adapted for false ceiling panels.
- Variable volume flow control.
- Unique locking system between connection bush and valve body.
- Suitable for rooms with a high air humidity (e.g. kitchen, bathroom).
- Simple removal for cleaning

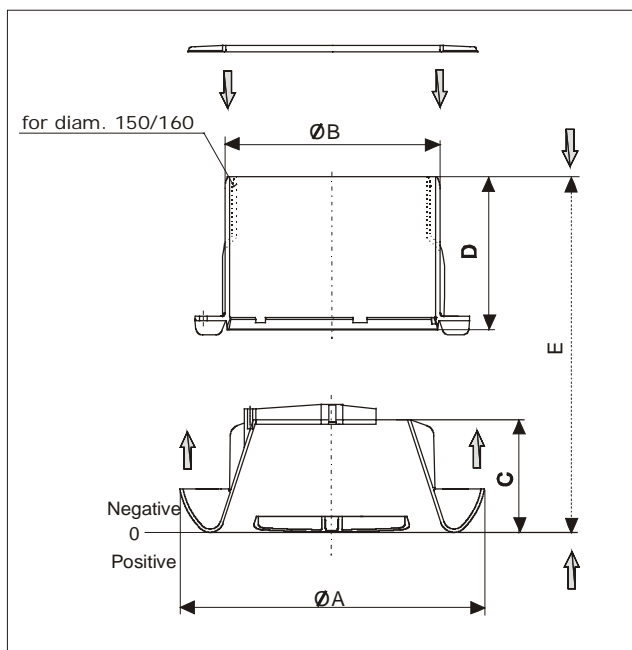

3.1b

DVKR

DIMENSIONS in mm

DVKR	A	B	C	D	E
100	141	99.5	52	70.5	84.5
125	167	124.5	52.5	70.5	84.5
150/160	202	149.5 / 159.5	52.5	70.5	84.5
200	240.3	199.5	52.0	70.5	84.5

The information contained in this brochure was current on the publication date. The Company reserves the right to make changes in details at any time without prior notice. In order to avoid misunderstandings, any interested party is advised to contact the Company checking for any changes in materials and/or information after this brochure was published.

Version 2006 www.decinternational.com

SUPPLY AIR VALVE DVKR

Pressure loss diagrams

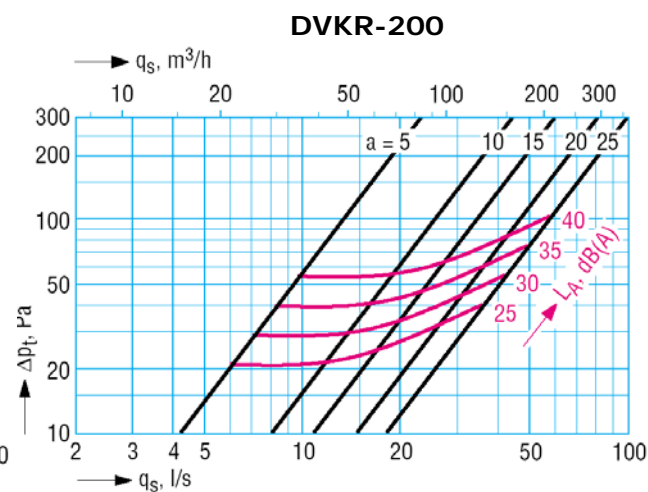
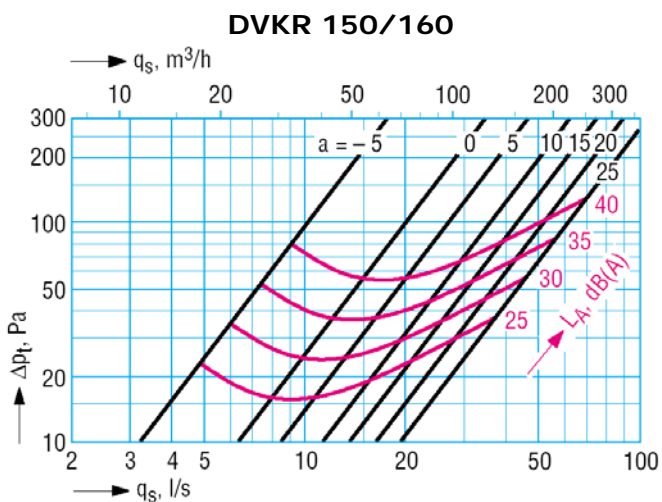
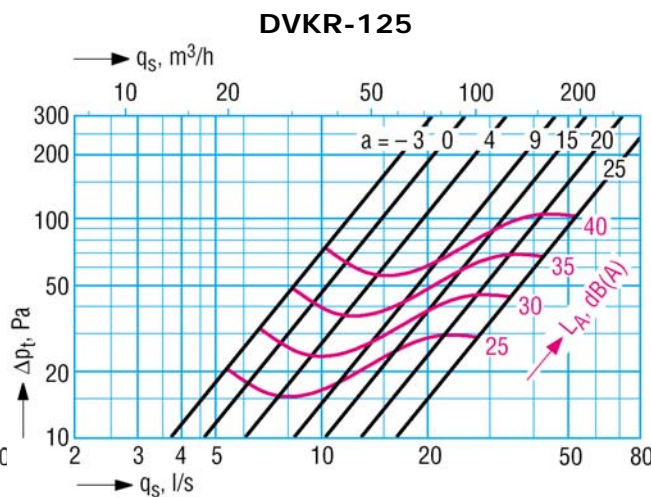
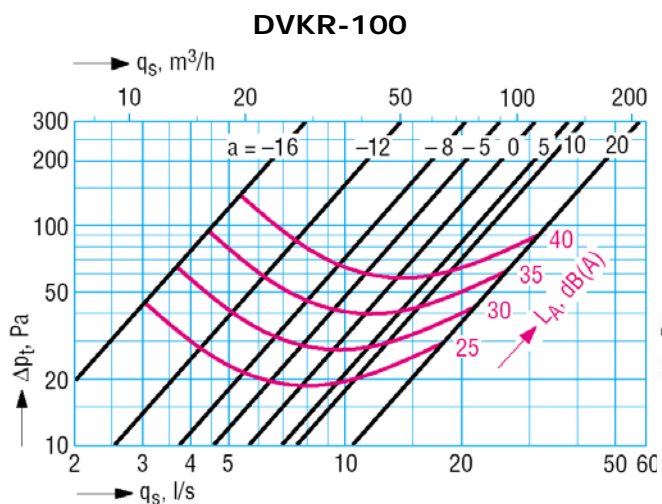

DVKR 3.1b

The information contained in this brochure was current on the publication date. The Company reserves the right to make changes in details at any time without prior notice. In order to avoid misunderstandings, any interested party is advised to contact the Company checking for any changes in materials and/or information after this brochure was published.

Version 2006 www.decinternational.com